

## 1558A Front View

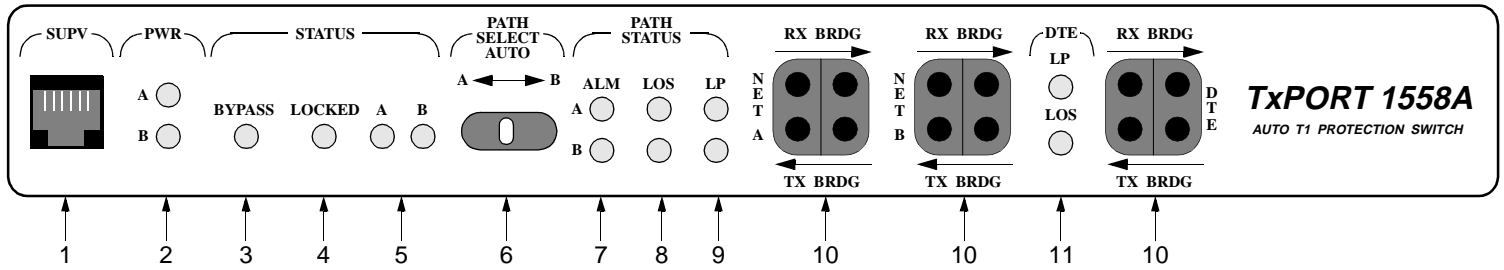

## 1558A Controls and Indicators

Index	Indicator	Description
1	SUPV	The Supervisory port allows the user to connect to the 1558A via a PC running the supplied LAPS software.
2	Power	One or both of these green LEDs will be ON when a nominal power source of -20 to -56 VDC is present on the PWR A and PWR B terminals.
3	Bypass	This red LED indicates whether the unit is in a 'bypass' mode of operation (ON if the unit has detected a CPU watchdog operational fault and OFF under normal operation).
4	Locked	When the 1558A has been manually forced to either the A or B path, this amber LED is on. Moving the Path Select switch back to the AUTO position turns off this LED and restores normal APS operation.
5	A / B	These amber status LEDs indicate which of the two T1 receive paths (A or B) is presently being utilized
6	Path Select Auto/A/B	The user can manually force and lock either the A or B path as the active path by moving this switch from the AUTO position to either the A or B position. The 1558A is now manually locked to this path and will not switch from it, even if the selected path is or will be in a failed state.
7	Alarm	These red LEDs indicate that the user definable alarm parameters (ES, CSES, LOS, and LOF) have been met or exceeded for Path A or Path B.
8	LOS	This amber LED indicates that no T1 pulses are being detected on the receive signal paths from the network for Path A or Path B.
9	Loop	This amber LED indicates that a loop has been activated for Path A or Path B.
10	Test Jacks	Bantam test access jacks and bridge/monitor jacks are provided to gain physical access to the T1 path for NET A, NET B, and the T1 DTE path.
11	Loop/LOS	The amber 'Loop' LED indicates that a loop has been activated on the DTE. The red 'LOS' LED indicates a loss of signal on the DTE.

## 1558A Rear View

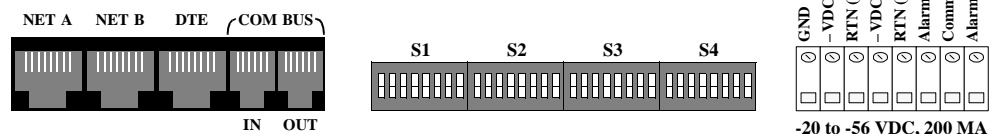

### Switch S1

DTE to NET Pass FDL  
 NET to DTE Pass FDL  
 DTE to NET Regen CRC  
 NET to DTE Regen CRC  
 Card Function Master  
 ARM from RAM  
 Boot Mode  
 Boot Mode

On ↑ / ↓ Off

DTE to NET Block FDL	NET to DTE Block FDL	DTE to NET Regen CRC	NET to DTE Regen CRC	Card Function Slave	ARM from ROM
<input type="checkbox"/>	<input type="checkbox"/>	<input type="checkbox"/>	<input type="checkbox"/>	<input type="checkbox"/>	<input type="checkbox"/>
S1-7	S1-8	Boot from			
Off	Off	Switches			
Off	On	Manager			
On	Off	RAM			
On	On	ROM			

**NOTE:** For future reference, all DIP switches on this sheet are provided with boxes to check according to the particular user selection. Factory default settings are shown underlined.

Switches S3 and S4 are shown on the back side.

### Switch S2

Framing Errors Disabled  
 LOS Disabled  
 NET A AMI  
 NET B AMI  
 DTE AMI  
 CSU Mode Disabled  
 Path Revert Enabled  
 DTE Framing D4

On ↑ / ↓ Off

Framing Errors Enabled  
 LOS Enabled  
 NET A B8ZS  
 NET B B8ZS  
 DTE B8ZS  
 CSU Mode Enabled  
 Path Revert Disabled  
 DTE Framing ESF

## 1558A Block Diagram

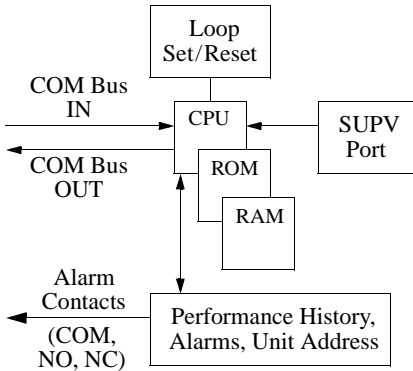
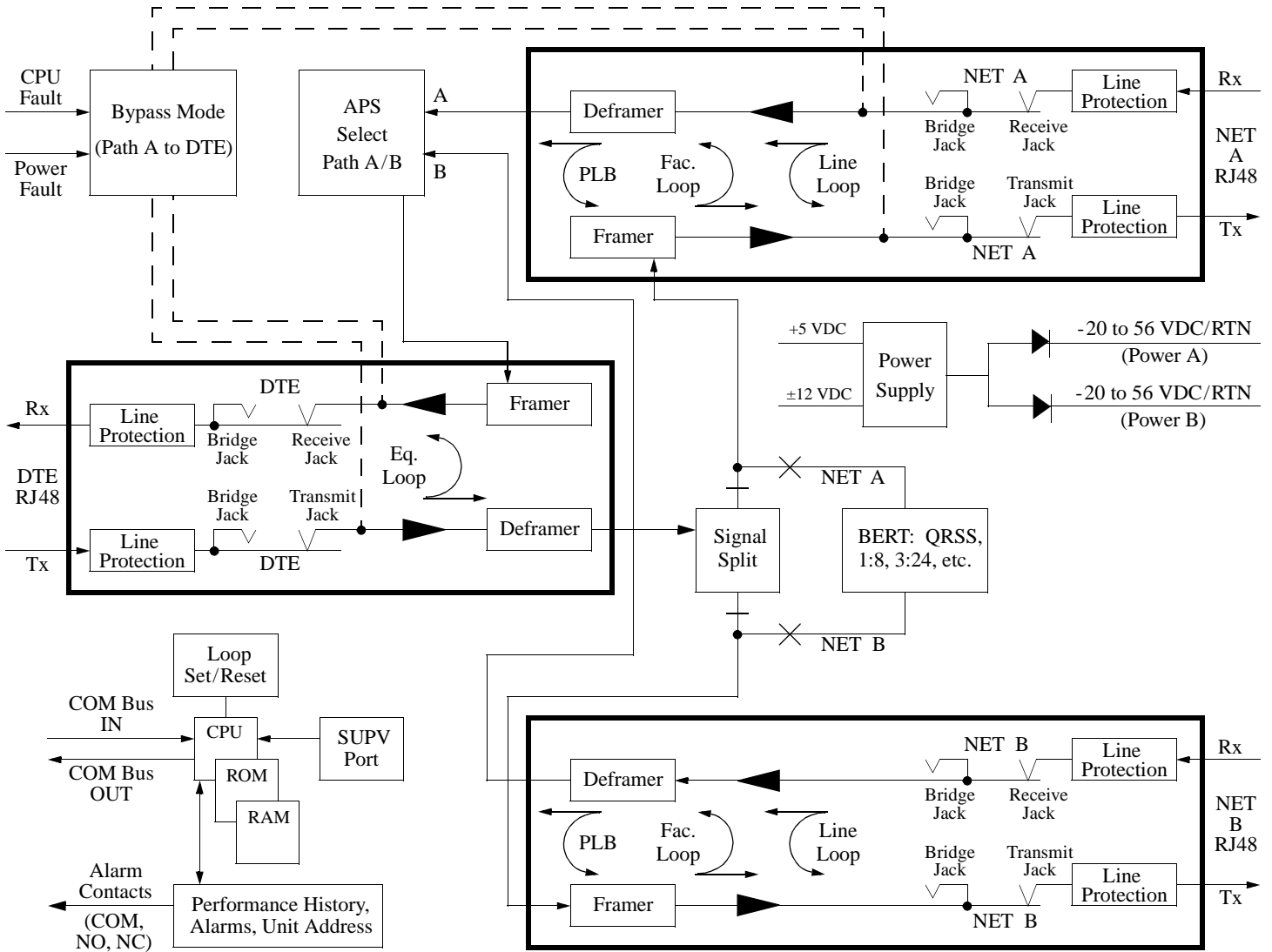

### Switch S3

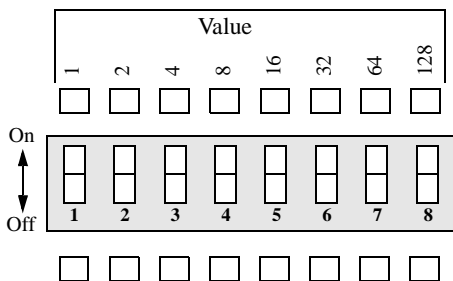

**NOTE:** Address values are additive for all switch positions set to the 'ON' position. For example, if positions 1 and 3 are set to the 'ON' position, the unit address is set to 5 (1+4).

Also note that Switch 3, Position 1 is factory wired to the ON position. This forces all Path A unit addresses to odd values and all Path B addresses to even values. The factory default is all switches set to 'OFF' (Path A address set to the ONE and Path B address set to Two)

### Switch S4

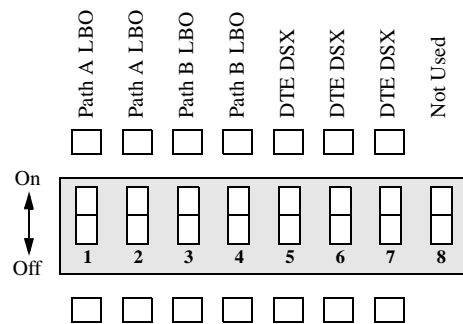

LBO	S4-1	S4-2	S4-3	S4-4	S4-5	S4-6	S4-7	DSX
0 dB	Off	Off	Off	Off	Off	Off	Off	133 ft
7.5 dB	Off	On	Off	On	Off	Off	On	266 ft
15 dB	On	Off	On	Off	Off	On	Off	399 ft
22.5 dB	On	On	On	On	Off	On	On	533 ft
					On	Off	Off	655 ft