

### Front Panel Description

1	<b>Status:</b> This green LED lights when the unit is powered and operating normally. The red LED lights if the alarm card circuitry detects an alarm condition from the FAR, NET, or DTE indicators or if an alarm threshold has been exceeded (if equipped with optional alarm card).
2	<b>ACO:</b> This red LED (only on units equipped with the optional alarm card) lights if the ‘alarm cut off’ switch is placed in the left ‘ON’ position. This indicates that the alarm relay contacts are disabled.
3	<b>ACO SW:</b> The alarm cut off switch controls the alarm relay circuitry. It is disabled in the left ‘ON’ position. The right ‘OFF’ position enables alarm reporting.
4	<b>Switch S1:</b> This 7-position DIP configuration switch is described on the reverse side.
5	<b>Switch S2:</b> This 7-position DIP configuration switch is described on the reverse side.
6	<b>Net Error:</b> This LED lights a minimum of 0.1 second if the internal alarm circuitry detects any of the following conditions from the incoming T1 signal – one or more bipolar violations (BPV), frame bit errors (FBE), cyclic redundancy check errors (CRC), or a loss of signal/out of frame (LOS/OOF) condition.
7	<b>Far Error:</b> This LED lights a minimum of 0.1 second if the internal alarm circuitry detects a yellow alarm signal from the far end terminal equipment. This condition occurs if the far end terminal is out of sync with the T1 signal from the network.
8	<b>DTE Error:</b> This LED lights a minimum of 0.1 second if the internal alarm circuitry detects any one of the following conditions from the DTE – one or more bipolar violations (BPV), frame bit errors (FBE), cyclic redundancy check errors (CRC), yellow alarm, low one’s density, or a loss of signal/out of frame condition.
9	<b>Loop:</b> This LED lights under the following conditions – the manual loop switch is in the ‘LOOP’ position, the unit receives an inband loop code for more than 5 seconds, or the unit receives an FDL loop message (PLB or LLB). The LED does not light if the test switch is placed in the ‘NRM’ position or if an inband or FDL unloop code is received.
10	<b>Test Switch:</b> This switch is used for local testing. In the local loop mode (LOOP), the unit loops the signal from the customer equipment (DTE in) back to the customer equipment (DTE out). It also loops the received signal from the T1 facility (NET IN) back to the T1 facility (NET OUT). When moved back to ‘NRM’, the local loopback is removed.
11	<b>Test Jacks:</b> These bantam jacks provide access to the T1 line on the DTE side as follows – the top 2 jacks break connection to the DTE and make connection to the unit in the direction of the network, the middle 2 ports are used for monitoring the signals passing through the unit (between the DTE and the network), and the bottom 2 ports break connection to the unit and make connection to the DTE.

### SPECIFICATIONS

#### Network Interface

Line Rate:	1.544 Mb/s (±50 bps)
Line Framing/Coding:	D4 or ESF / AMI or B8ZS
Line Impedance:	balanced 100 Ω (±5%)
Input Signal:	DS1, +1 to -30 dB (ALBO)
Output Signal:	3.0 V (±15%) base-peak into 100 Ω
Line Protection:	1000 V lightning, fused input/output
Jitter Control:	per TR62411 and T1.403
Pulse Density:	per TR62411

#### Equipment Interface

Line Rate:	1.544 Mb/s (±50 bps)
Line Framing/Coding:	D4 or ESF / AMI or B8ZS
Line Impedance:	balanced 100 Ω (±5%)
Input Signal:	DSX1 to -6 dB
Output Signal:	Selectable DSX1 level from 0 to 655 feet
Line Protection:	1000 V lightning

#### Mechanical

Mounting:	19" rack (23" available)
Dimensions:	19" W, 7" H, 10.5" D
Weight:	9.5 lbs.

#### Industry Standards

FCC Compliance:	Part 15, Subpart B, Class A
FCC Part 68 Reg:	FXKUSA- 75690-DE-N
NRTL	UL 1459
CSA Certified:	LR62298
DOC/CSO3:	1653 5649 A
TR54016	September 1989
TR62411	
ANSI T1.403	

#### Environmental

Operating Temp:	0° to 50° C (32° to 122°F)
Storage Temp:	-20° to 85° C (-4° to 185°F)
Humidity:	95% max (non-condensing)

## TxPORT 1051-2 Chassis Rear View

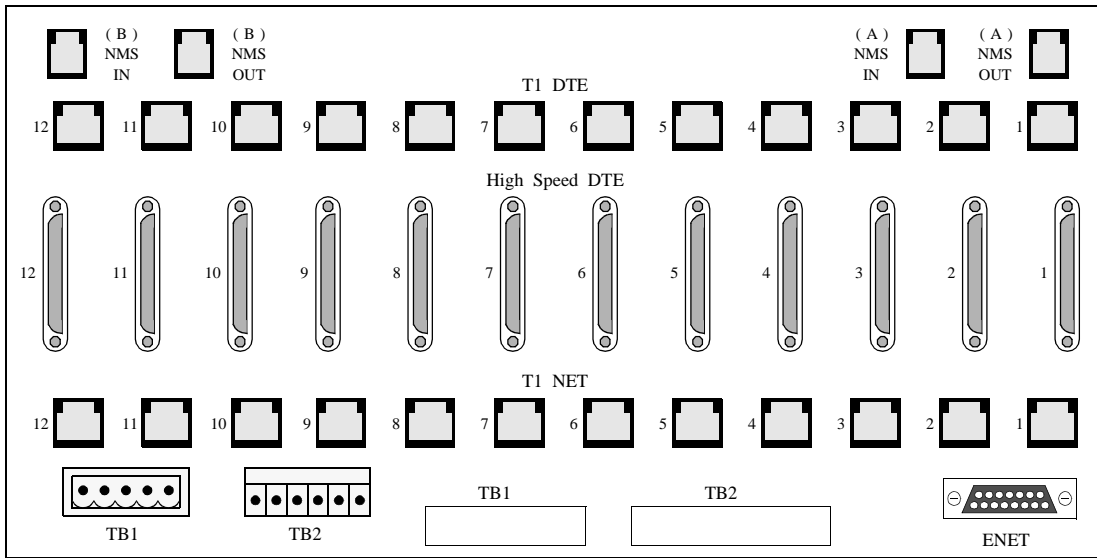

### Chassis Connections

Pin	T1 DTE	T1 NET
1	Data Out	Data In
2	Data Out	Data In
3	Not used	Not used
4	Data In	Data Out
5	Data In	Data Out
6	Not used	Not used
7, 8	Signal Gnd	Signal Gnd

Pin	NMS In	NMS Out
1	Not Used	Not Used
2	Signal Gnd	Signal Gnd
3	Data Out	Data Out
4	Data In	Not Used
5	Signal Gnd	Signal Gnd
6	Not Used	Not Used

### Switch S1 (front panel)

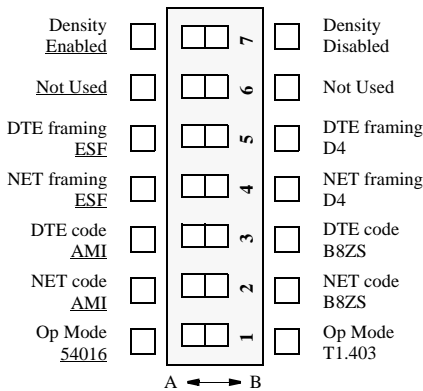

### Switch S2 (front panel)

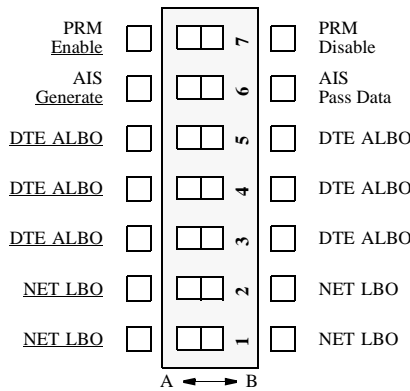

### DTE ALBO

S2-3	S2-4	S2-5	Distance
A	A	A	0-133
B	B	B	134-266
A	B	B	267-399
B	A	B	400-533
A	A	B	534-655

### Network LBO

S2-1	S2-2	Attenuation
A	A	0 dB
A	B	-7.5 dB
B	A	-15.0 dB
B	B	-22.5 dB

*NOTE: The 'A' position is the factory default for all switch settings. If a particular user configuration requires that a switch be placed in the 'B' direction, then mark this sheet for future reference.*

### Switch S1

1	<b>ESF Mode: 54016</b> - the unit responds only to 54016 CSU messages. T1.403 mode - the unit responds to ANSI loop/unloop commands and generates a PRM every second, but will not respond to 54016 messages.
2	<b>Network Line Coding:</b> Sets the NET line coding (including conversion).
3	<b>DTE Line Coding:</b> Sets DTE line coding (including conversion)
4	<b>Network Line Framing:</b> Sets the CSU to the framing of the network line. In the ESF mode, the unit responds to all T1.403 or 54016 messages.
5	<b>DTE Line Framing:</b> Sets the CSU to the framing of the DTE line.
7	<b>Density (zero suppression mode):</b> Enabled allows ones density control after 15 successive zeros from the DTE (per TR62411). Disabled ignores density control and allows 175 zeros to pass towards the network.

### Switch S2

1-2	<b>Network LBO:</b> Sets the network signal level of data transmitted towards the T1 facility. Refer to the table.
3-5	<b>DTE ALBO:</b> Sets the DTE line build out transmit value towards the customer equipment. The value should match the cable length from the CSU DTE port to the attached equipment. Refer to the table above.
6	<b>AIS Enable:</b> Enables sending an alarm indication signal during an active payload loopback. <u>A</u> - generate AIS to DTE during remote loop; <u>B</u> - Pass received network signal to DTE.
7	<b>PRM Enable:</b> Enables sending a PRM during an AIS. If the unit detects loss of sync from the DTE, an unframed all ones signal is generated to the T1 facility. If Switch S2-6 is set to generate AIS and Switch S1-1 is set for T1.403 operation, the unit interrupts the AIS signal with a PRM once a second.

### Loopbacks

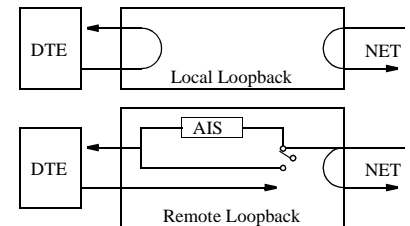

The 2010 can be looped remotely by generating towards it a standard CSU line loopback code (00001 repeating for 5 seconds, framed or unframed). Once looped, the received signal from the T1 facility (NET IN) is regenerated and transmitted back to the T1 facility (NET OUT).

The 2010 can be unlooped remotely by generating towards it a standard CSU line unloop code (001 repeating for 5 seconds, framed or unframed). The 2010 responds to FDL loop and unloop command messages.

# TXPORT

TRANSPORT

TxPORT Customer Service  
127 Jetplex Circle  
Madison, Alabama 35758

Customer Service Returns:  
800-926-0085, ext. 227

Product Technical Support  
(8 a.m. to 5 p.m. Central)  
800-285-2755 or  
205-772-3770, ext. 255

Emergency After Hours:  
800-285-2755  
Manager: 205-603-2194