

Introduction

**2010
ESF
CSU**



***Reference Manual
34-00204
1st Edition, Rev 1.02***

Table of Contents

General

Introduction	1-1
Specifications	1-1
FCC Requirements	1-2
Canadian Emissions Requirements	1-3
Warranty	1-3
TxPORT Customer Service	1-3
Ordering Numbers	1-4

Installation

Introduction	2-1
Safety Summary	2-1
Unpacking and Inspection	2-1
Supplied Material	2-1
Mounting	2-1
Unit Configuration	2-1
Configuration Switch S1	2-2
Configuration Switch S2	2-2
Configuration Switch S3	2-3
Alarm/ACO Card (Option)	2-3
DTE Connection	2-4
Network Connection	2-4
Alarm Connection	2-4
Power Connection	2-4

Operation

Introduction	3-1
Front Panel Descriptions	3-1
General Status Indicators	3-1
Alarm Controls and Indicators	3-1
Test Controls and Indicators	3-2
Front Panel Testing	3-2
Test Switch	3-2
Test Access Jacks	3-2
Terminal Operation	3-2

Copyright/liability

Copyright

© 1995 TxPORT, All rights reserved. No part of this publication may be reproduced, transmitted, transcribed, stored in a retrieval system, or translated into any language in any form by any means without the written permission of TxPORT.

Reorder # 34-00204

1st Edition, February 1995

TxPORT shall not be liable for errors contained herein or for incidental or consequential damages in connection with the furnishing, performance, or use of this material. TxPORT reserves the right to revise this publication from time to time and make changes in content without obligation to notify any person of such revision changes.

Contents of this publication may be preliminary and/or may be changed at any time without notice and shall not be regarded as a warranty.

Documentation Disclaimer

TxPORT makes no representation or warranties of any kind whatsoever with respect to the contents hereof and specifically disclaims any implied warranties of merchantability or fitness for any particular purpose.

General

1.0 Introduction

The TxPORT 2010 ESF CSU provides an economical solution for interfacing a metallic T1 facility to customer provided T1 equipment. The 2010 supports ANSI T1.403 or AT&T 54016 ESF CSU requirements.

The 2010 may be ordered as a stand-alone unit or as a modular card for mounting in a chassis. When the 2010 is paired with a TxPORT 2000 CSU at the far end, the 2010 can be managed over the TxPORT EM8000 element manager network.

For applications requiring the use of alarm contacts, the unit may be ordered with an ACO and alarm card. The 2010 has primary and secondary surge protection on both the network and DTE side (meeting UL 1459 requirements).

The unit provides ALBO circuitry on the network path and DSX circuitry on the DTE receive paths. The network ALBO supports a receive range of +1 dB to -30 dB. The DTE supports DSX1 signal ranges up to 655 feet.

The unit also provides LBO circuitry on both network and DTE. The network transmit LBO is user selectable (0, -7.5, -15, and -22.5 dB). The DTE transmit LBO is user selectable in four incremental ranges from 0 to 655 feet.

1.1 Specifications

Network Interface

Line Rate:	1.544 Mb/s (± 50 bps)
Line Framing:	D4 or ESF
Line Code:	AMI or B8ZS
Line Impedance:	balanced 100 Ω ($\pm 5\%$)
Input Signal:	DS1, +1 to -30 dB (ALBO)
Output Signal:	3.0 V ($\pm 15\%$) base-peak into 100 $\frac{3}{4}$
Line Build Out:	0, -7.5, -15, and -22.5 dB attenuation
Line Protection:	1000 V lightning, fused input/output
Jitter Control:	per TR62411 and T1.403
Pulse Density:	per TR62411

TxPORT 2010 CSU

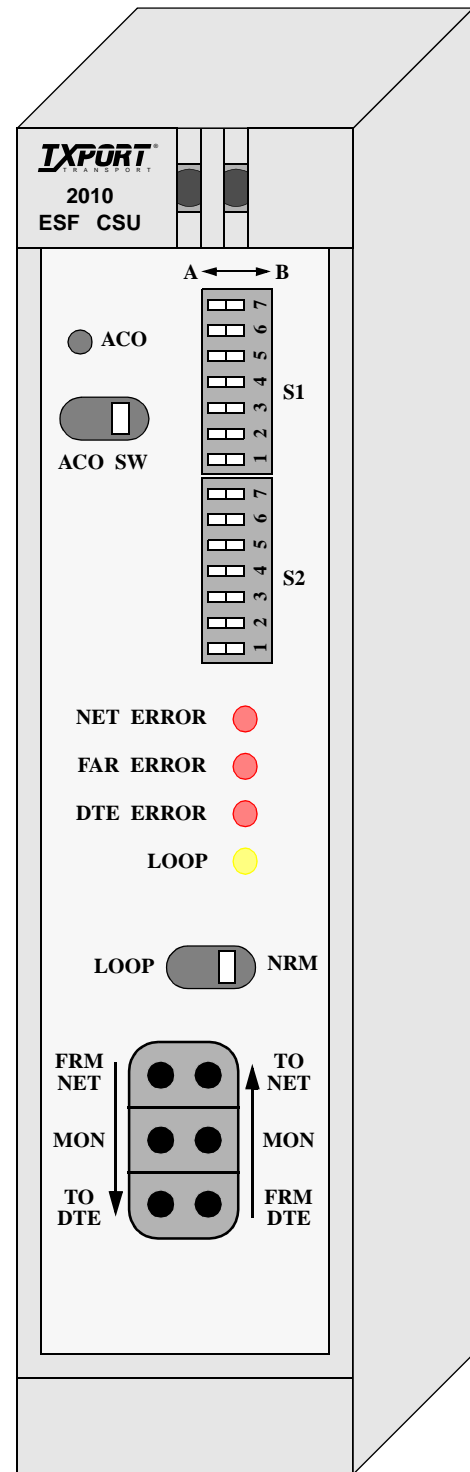

Equipment Interface

Line Rate:	1.544 Mb/s (± 50 bps)
Line Framing:	D4 or ESF
Line Code:	AMI or B8ZS
Line Impedance:	balanced 100 Ω ($\pm 5\%$)
Input Signal:	DSX1 to -6 dB
Output Signal:	Selectable DSX1 level from 0 to 655 feet in 4 incremental levels
Line Protection:	1000 V lightning, fused input/output

Mechanical

Stand-alone Unit:

Mounting:	desktop, wall, horizontal rack, or vertical rack
Dimensions:	1.72" W, 6.8" H, 10.5" D
Weight:	2 lbs.

12-slot Chassis:

Mounting:	19" rack (23" available)
Dimensions:	19" W, 7" H, 10.5" D
Weight:	9.5 lbs.

Environmental

Operating Temp:	0° to 50° C (32° to 122°F)
Storage Temp:	-20° to 85° C (-4° to 185°F)
Humidity:	95% max (non-condensing)

Compatibility

TR54016	September 1989
TR62411	
ANSI T1.403	

Industry Standards

FCC Compliance:	Part 15, Subpart B, Class A
FCC Part 68 Reg:	FXKUSA- 75690-DE-N
UL Approved	
CSA Certified:	LR62298
DOC/CSO3:	1653 5649 A

1.2 FCC Requirements



WARNING: Changes or modifications to this unit not expressly approved by the party responsible for compliance could void the user's authority to operate the equipment.

This device complies with Part 15 of the FCC rules. Operation is subject to the following two conditions:

- 1) This device may not cause harmful interference.
- 2) This device must accept any interference received, including interference that may cause undesired operation.

This equipment has been tested and found to comply with the limits for a Class A digital device, pursuant to Part 15 of FCC Rules. These limits are designed to provide reasonable protection against harmful interference when the equipment is operated in a commercial environment. This equipment generates, uses, and can radiate radio frequency energy and if not installed and used in accordance with the instruction manual, may cause harmful interference to radio communications. Operation of this equipment in a residential area is likely to cause harmful interference. The user will be required to correct the interference at his own expense.

Shielded cables must be used with this unit to ensure compliance with the Class A FCC limits.

Notice to Users of 1.544 Mb/s Service: The following instructions are provided to ensure compliance with FCC Rules, Part 68:

- 1) All direct connections to T1 lines must be made using standard plugs and jacks.
- 2) Before connecting your unit, you must inform the local telephone company of the following information:

Port ID: P/N/12 - 00635

REN/SOC: 6.0 N

FIC (Facility Interface Code):

04DU9-BN	04DU9-DN
04DU9-1KN	04DU9-1SN
04DU9-1ZN	

USOC jack: RJ48C (stand-alone version)
RJ48H (chassis version)

- 3) If the unit appears to be malfunctioning, it should be disconnected from the telephone lines until you learn whether the source of trouble is your equipment or the tele-

phone line. If your equipment needs repair, it should not be reconnected until it is repaired.

4) The unit has been designed to prevent harm to the T1 network. If the telephone company finds that the equipment is exceeding tolerable parameters, they can temporarily disconnect service. In this case, the telephone company will give you advance notice, if possible.

5) Under FCC rules, no customer is authorized to repair this equipment. This restriction applies regardless of whether the equipment is in or out of warranty.

6) If the telephone company alters their equipment in a manner that will affect the use of this device, they must give you advance warning so that you can have the opportunity for uninterrupted service. You will be advised of your right to file a complaint with the FCC.

7) The attached affidavit must be completed by the installer.

8) In the event of equipment malfunction, all repairs should be performed by our company or an authorized agent. It is the responsibility of users requiring service to report the need for service to our company or to one of our authorized agents.

1.3 Canadian Emissions Requirements

This digital apparatus does not exceed the Class A limits for radio noise emissions from digital apparatus set out in the Radio Interference Regulations of the Canadian Department of Communications.

Note: End users should use existing 48 VDC battery sources or a CSA certified power supply.

Le présent appareil numérique n'émet pas de bruits radioélectriques dépassant les limites applicables aux appareils numériques (de la class A) prescrites dans le Règlement sur le brouillage radioélectrique édicté par le ministère des Communications du Canada.

1.4 Warranty

TxPORT warrants each unit against defects in material and workmanship for a period of five years from the date the unit was shipped to the customer. If the unit malfunctions at any time during the warranty period, TxPORT will repair, or at TxPORT's option, replace the unit free of charge.

The remedies listed herein are the users sole and exclusive remedies. TxPORT shall not be liable for any indirect, direct, incidental or consequential damages. The owner must

return the unit to the factory, shipping prepaid and packaged to the best commercial standard for electronic equipment. TxPORT will pay shipping charges for delivery on return. The customer is responsible for mode and cost of shipment to TxPORT. This warranty does not apply if the unit has been damaged by accident, misuse or as a result of service or modification by other than TxPORT personnel.

When returning the unit for warranty work, a Return Material Authorization (RMA) number must be obtained from customer service (refer to [Section 1.5](#) for the phone numbers). When calling TxPORT to obtain a Return Material Authorization number or to arrange service, please have the following information available:

- Model number(s) and serial number(s) for the unit(s).
- Reason for return and symptoms of problem.
- Warranty status (if known).
- Purchase order number to cover charges for out-of-warranty items.
- Name and phone number of person we can contact if we have questions about the unit(s).
- Mode of shipment required (second day air is the normal mode of shipment for all returned material unless otherwise specified).

As soon as TxPORT has the above information, the RMA that must accompany the item(s) returned can be issued.

1.5 TxPORT Customer Service

TxPORT

127 Jetplex Circle
Madison, Alabama 35758

Telephone Number: 800-926-0085 or
205-772-3770

Sales/Administration FAX: 205-772-3388

Manufacturing FAX: 205-772-8280

Customer Service Returns: 800-926-0085, ext. 227

Product Support

Normal Hours (8 a.m. to 5 p.m. Central Time, Mon. – Fri.)

Telephone Number: 800-285-2755, ext. 255 or
205-772-3770, ext. 255

Emergency (Nights / Weekends / Holidays):

800-285-2755
205-603-2194 (Manager)

1.6 Ordering Numbers

The unit is shipped from the factory with the 2010 CSU reference manual. Refer to [Table 1-2 on page 4](#) for the optional equipment part numbers.

The part numbers for the stand-alone unit and the modular chassis unit are shown in the following table:

Table 1-1 2010 Ordering Numbers

Part Number	Description
F-2010-100-11 <u>CD</u>	2010 ESF CSU Stand-alone Unit
<u>C</u>	<u>Backplane Option</u>
1	RJ48C NET / RJ48C DTE
2	RJ48C NET / DB15 DTE
3	DB15 NET / DB15 DTE
<u>D</u>	<u>ACO Option</u>
0	without ACO
1	with ACO
9-2000-001-1	19" single unit rack mount bracket
9-2000-001-2	19" dual rack mount bracket
9-2000-002-1	23" single unit rack mount bracket
9-2000-002-2	23" dual rack mount bracket
F-2010-101-11 <u>C0</u>	2010 ESF CSU Module (chassis)
<u>C</u>	<u>ACO Option</u>
1	1051 chassis without ACO
2	1051 chassis with ACO
3	K-type chassis without ACO
4	K-type chassis with ACO

For example, the default part number for the stand-alone unit is 'F-2010-100--1110'. This is a unit with RJ48C backplane connectors for both the network and DTE and without ACO.

The following accessories may also be needed for the installation and operation of the 2010 CSU.

Table 1-2 Optional Equipment

Part Number	Description
Cables	
9-1001-042-1	Dual 6-pin modular to DB25 male
9-1001-042-2	Dual 6-pin modular to DB25 female
33-00085	Bantam to bantam test cord - red
33-00086	Bantam to bantam test cord - black
Mounting	
F-1051-000--112	1051 12-slot chassis (RJ48C)
9-2000-036--1	Stand-alone to rack mount conversion module with DB25 to 6-pin adapter
Power Supplies	
30-00087	200 mA stand-alone wall mount -48 V power supply
F-1040-000--111	Single 2 A, -48 VDC power supply
F-1040-000--112	Redundant 2 A, -48 VDC power supplies
F-1041-000--110	1041 redundant power shelf (w/o supplies)
9-1000-48V-1	Spare -48 VDC power supply (holds 2)
F-1200-000--11	1200 power supply with redundant -48 VDC, 5 A with fuse panel
Misc.	
9-8000-001-1	EM8000 with manual on 3-1/2 inch disk
9-8000-001-2	(DOS and UNIX version, respectively)

Installation

2.0 Introduction

This chapter contains information and instructions required to prepare the TxPORT 2010 ESF CSU for use. Included are initial inspection procedures, mounting instructions, configuration guidelines, connection instructions, and powering information.

NOTE: Throughout this manual, all factory default settings will be underlined.

2.1 Safety Summary

This manual contains information and warnings which must be followed by the user to ensure safe operation and to retain the equipment in a safe condition.



The WARNING sign denotes a hazard to the operator. It calls attention to a procedure or practice which, if not correctly performed or adhered to, could result in injury or loss of life. Do not proceed beyond a WARNING sign until the indicated conditions are fully understood and met.

2.2 Unpacking and Inspection

This unit is carefully packaged to prevent damage in shipment. Upon receipt, inspect the shipping container for damage. If the shipping container or cushioning material is damaged, notify the carrier immediately and make a notation on the delivery receipt that the container was damaged (if possible, obtain the signature and name of the person making delivery).

Retain the packaging material until the contents of the shipment have been checked for completeness and the instrument has been checked both mechanically and electrically.

If the contents of the shipment are incomplete or, if there is mechanical damage or defect, notify TxPORT. If the shipping container is also damaged, or the cushioning material shows signs of stress, notify the carrier of the damage as well as TxPORT. Keep the shipping materials for carrier's inspection. TxPORT will arrange for repair or replacement without waiting for claim settlement.

2.3 Supplied Materials

The TxPORT 2010 CSU is shipped from the factory with the 2010 CSU reference manual. The user may also require the following additional materials for the installation and operation of the 2010 CSU.

- -48 VDC power source
- Network and DTE interface cables
- Bantam test cables
- 20-gauge stranded wire (or similar) for DC power and alarm connection

The interface requirements of any application may be met by using the appropriate cable. Standard cables and ordering numbers are listed in [Table 1-1 on page 1-4](#). Contact TxPORT for any needed assistance in cable selection.

2.4 Mounting

The TxPORT 2010 CSU is a modular unit that plugs into either a single unit housing or into a chassis that holds up to 12 units. Single units are designed for stand-alone desktop use, wall mounting, or chassis mounting (in either a vertical or horizontal orientation). The unit uses an interchangeable front panel to accommodate the chassis card cage.

Up to 12 units may be inserted into a chassis and the chassis may be installed in a 19" or 23" rack using four screws. Connections are made from the rear of the chassis.

2.5 Unit Configuration

The following sections describe the configuration of the 2010 CSU. The unit was designed to be operated from manual switch control.

On power up, the unit is configured to the hardware settings of the DIP configuration switches. Changes to these settings will not take effect until the unit has been reset. This may be accomplished either by removing and then reapplying power or by quickly placing the test switch in the 'Loop' position and then back to 'Normal'.

S2-3	S2-4	S2-5	DTE ALBO Level
A	A	A	0-133 feet
B	B	B	134-266 feet
A	B	B	267-399 feet
B	A	B	400-533 feet
A	A	B	534-655 feet

S2-6: This position enables the sending of an alarm indication signal (AIS) during an active payload loopback. The unit can be optioned to generate an alarm indication signal (unframed all ones) to the DTE during remote loop or to pass the received network signal to the DTE on remote loop.

A - Generate AIS to DTE B - Pass signal to DTE

S2-7: This position enables the sending of a PRM (performance report message) during an alarm indication signal (AIS). If the unit detects a loss of sync from the DTE, an unframed all ones signal is generated to the T1 facility. If Switch S2-6 is set to generate AIS and Switch S1-1 is set for T1.403 operation, the unit interrupts the AIS signal with a PRM once a second.

A - PRM enabled B - PRM disabled

2.5.3 Configuration Switch S3

Switch S3 is a 2-position slide switch (refer to [Figure 2-1](#)). It selects the DTE side transmit and receive pair configuration for either a TxPORT (TX) shelf or any other manufacturer's shelf (KX). This switch is factory set and should not be changed.

2.5.4 ACO/Alarm Card (Option)

The optional ACO/alarm card monitors the 'NET', 'FAR', and 'DTE' alarm indicators for either an 'alarm active' or an 'alarm clear' condition and provides closure contact points on the rear panel. The corresponding front panel LED lights when an alarm condition is detected.

The alarm card circuitry scans the status (on/off) of the NET, FAR, and DTE indicators 10 times a second (100 ms windows). The card declares an alarm if one or more indicators are on for 100 consecutive 0.1 second samplings (10 seconds). When this happens, the red 'Status' indicator turns on until no alarm conditions are detected for more than 100 consecutive 0.1 second samplings (another 10 seconds).

Alarm Relay: The rear panel alarm relay contacts may be configured as normally open (NO) or normally closed (NC) depending on the setting of the optional alarm card jumper

shown below. This 3-pin jumper straps the ACO alarm contact. Position jumper over pins 1 & 2 for normally open operation (closes on alarm) or over pins 2 & 3 for normally closed operation (opens on alarm).

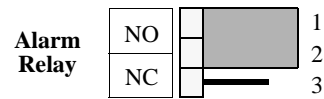
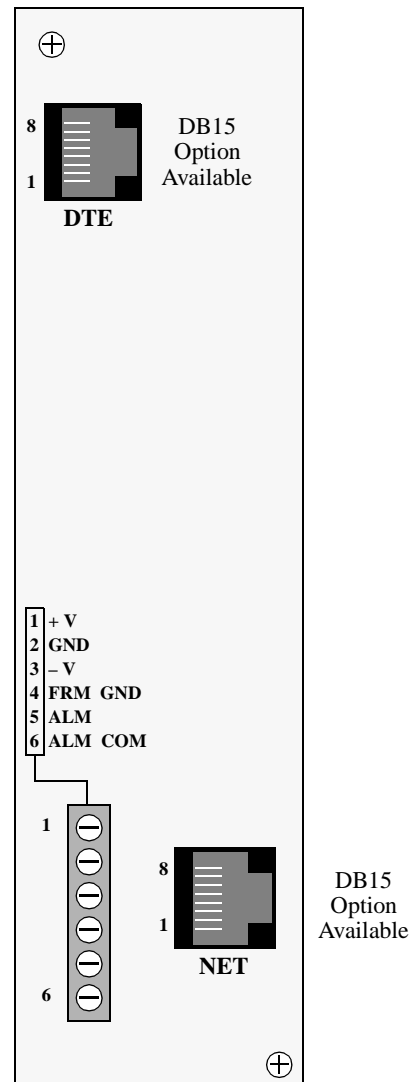

Figure 2-2 2010 CSU Rear Panel



2.6 DTE Connection

The DTE connection is provided on the rear panel (refer to [Figure 2-2 on page 2-3](#)). The equipment side DTE interface of the CSU is a DSX interface. The DTE line build out level should be set as instructed in [Section 2.5.2 on page 2-2](#).

The DTE physical interface for both the stand-alone unit and the chassis mounted unit is a standard RJ48C 8-pin modular jack. A DB15 backplane is also an option for the network and DTE interfaces. The pinout assignments are shown in the following table:

Pin	RJ48 Interface	Pin	DB15 Interface
1	Data Out	1	Data In
2	Data Out	2	Frame Ground
3/6	Not Used	3	Data Out
4	Data In	4	Frame Ground
5	Data In	9	Data In
7/8	Chassis Ground	11	Data Out

2.7 Network Connection

The network side of the CSU is referred to as the network interface. This interface contains an ALBO to allow the unit to be located a substantial distance away from the telco network interface (receive signal level down to -27 dB).

The network interface line build out (LBO) levels should be adjusted as instructed in [Section 2.5.2 on page 2-2](#). The maximum suggested cable lengths for units connected to the network are listed in the following table.

Cable Type	Loss per 1000'	Max. Length
26 gauge PIC	6.8 dB	4,400 ft
24 gauge PIC	5.4 dB	5,500 ft
22 gauge PIC	4.2 dB	7,100 ft
19 gauge PIC	3.0 dB	10,000 ft

Calculations are based on a cable temperature of 70°F, 0.083 uF/mile capacitance, a 27 dB loss, and a 100 Ω, non-loaded, twisted pair cable; PIC refers to Plastic Insulated Cable.

The network physical interface for both the stand-alone unit and the chassis mounted unit is a standard RJ48C, 8-pin modular jack. A DB15 backplane is also an option for the network and DTE interfaces. The pinout assignments are shown in the following table:

Pin	RJ48 Interface	Pin	DB15 Interface
1	Data In	1	Data Out
2	Data In	2	Not Used
3/6	Not Used	3	Data In
4	Data Out	4	Not Used
5	Data Out	9	Data Out
7/8	Chassis Ground	11	Data In

Network Disconnection: In accordance with FCC Part 68.218(b), the user must notify the telephone company prior to disconnecting the CSU.

2.8 Alarm Connection

A rear panel terminal strip provides connections for the alarm leads. Alarm relay contacts are provided (with the optional alarm card) to permit connection to a remote indicating device. The connection is made on pins 5 and 6 as shown below in [Table 2-3](#). Pin 5 is configured to operate in a 'normally open' or 'normally closed' mode, depending on the setting of the alarm relay jumper.

Table 2-3 Power & Alarm Connector

Pin	Description
1	48 VDC return
2	Signal Ground
3	-48 VDC
4	Frame Ground
5	Alarm Contact
6	Alarm Common

2.9 Power Connection

The 2010 is designed to operate from either a -24 VDC source (± 3 V, 80 mA) or from a -48 VDC source (± 6 V, 45 mA). The unit will operate over a voltage input range of -20 to -55 VDC. The chassis module of the 2010 unit obtains its power from the 12-position shelf wiring connections.

Connections are made on the rear panel power and alarm terminal strip. All terminal strip connections are made with 20-gauge stranded (or similar) wire. The contacts are rated at 0.6 Amp AC or 2.0 Amp DC.

Operation

3.0 Introduction

This chapter describes the front panel operation and test features of the TxPORT 2010 ESF CSU. These controls and indicators are described below. A section is also included describing the performance statistics which are collected when the 2010 is on the far end of a TxPORT product with an embedded terminal interface.

3.1 Front Panel Descriptions

This section describes the controls and indicators found on the 2010 CSU front panel. The unit uses LEDs to convey major alarm conditions and looping status, a network test switch, and test jacks. The two DIP configuration switches are described in [Section 2.5 on page 2-1](#). The following descriptions are indexed to [Figure 3-1](#).

3.1.1 General Status Indicators

1) **STATUS:** The CSU has two LED indicators on the front panel bezel that are exposed whether the access door is open or closed. These general status LEDs provide a quick check of the CSU's operating condition (Go or No Go).

The green LED lights when the unit is powered and operating normally. The red LED lights if the alarm card circuitry detects an alarm condition from the FAR, NET, or DTE indicators or if an alarm threshold has been exceeded (if equipped with optional alarm card). The green LED shuts off if the red LED is on.

3.1.2 Alarm Controls and Indicators

2) **ACO:** This red LED (only on units equipped with the optional alarm card) lights if the 'alarm cut off' switch is placed in the left 'on' position. It indicates that the alarm relay contacts are disabled.

3) **ACO SW:** This switch controls the alarm relay circuitry. This circuitry is deactivated in the left 'on' position. The right 'off' position enables alarm reporting.

4) **NET ERROR:** This LED lights a minimum of 0.1 second if the internal alarm circuitry detects any of the following conditions from the incoming T1 signal: one or more BPVs, FBES, CRCs, or loss of signal/loss of sync.

Figure 3-1 2010 CSU Front Panel

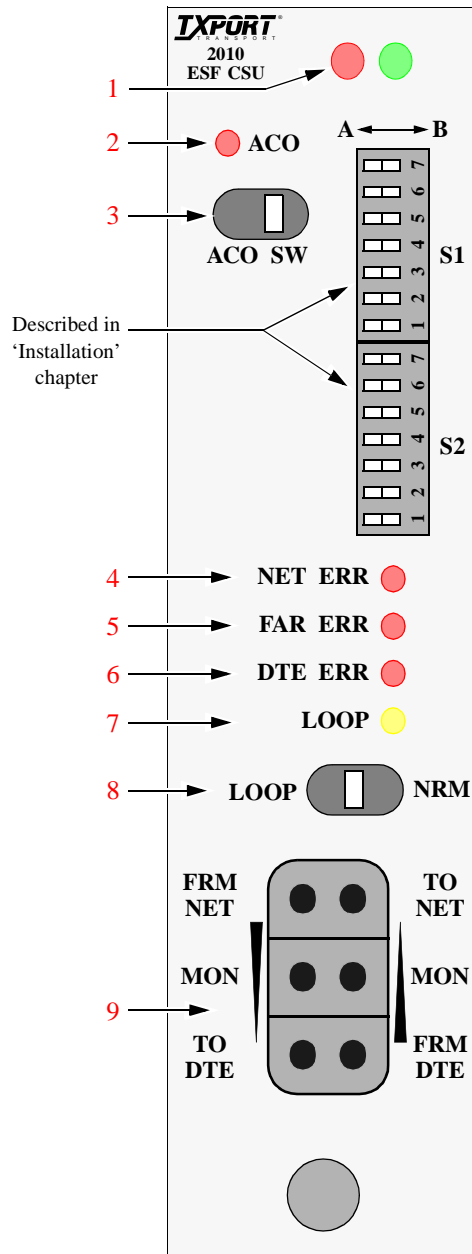

5) **FAR ERROR:** This LED lights a minimum of 0.1 second if the internal alarm circuitry detects a remote (yellow) alarm signal from the far end terminal equipment. This condition occurs if the far end terminal is out of sync with the T1 signal from the network. The format for a remote alarm is bit 2 set to 1 in each DS0 (D4 mode) or 8 ones/8 zeros in the facility data link (ESF mode).

6) **DTE ERROR:** This LED lights a minimum of 0.1 second if the internal alarm circuitry detects any one of the

following conditions from the DTE: one or more BPVs, FBEs, CRCs, a yellow alarm, low ones density, or loss of signal/loss of sync.

3.1.3 Test Controls and Indicators

7) **Loop:** This yellow LED lights under the following conditions: if the manual loop switch is placed in the 'LOOP' position, if the unit receives an inband loop code for > 5 seconds, or if the unit receives an FDL loop message (PLB or LLB). The LED does not light if the test switch is placed in the 'NRM' position or if an inband or FDL unloop code is received.

8) **Test Switch:** This switch is used for local testing. Refer to [Section 3.2.1](#) for further information.

9) **Test Jacks:** Bantam jacks are provided for access to the T1 line on the DTE side of the CSU. Refer to [Section 3.2.2](#) for further information.

3.2 Front Panel Testing

The previous section gave a brief description of each front panel control and LED indicator. This section explains the front panel test functions. Refer to [Figure 3-1 on page 3-1](#) for locations.

3.2.1 Test Switch

Local Loop: In the local loop mode (LOOP), the unit loops the signal from the customer equipment (DTE IN) back to the customer equipment (DTE OUT). It also loops the received signal from the T1 facility (NET IN) back to the T1 facility (NET OUT). When moved back to 'NRM', the local loopback is removed.

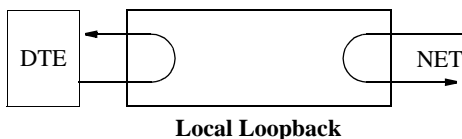

Remote Loop: The unit can be looped remotely by generating towards it a standard CSU line loopback code (00001 repeating for 5 seconds, framed or unframed). Once it is looped, the received signal from the T1 facility (NET IN) is regenerated and transmitted back to the T1 facility (NET OUT). The unit can be unlooped remotely by generating

towards it a standard CSU line unloop code (001 repeating for 5 seconds, framed or unframed).

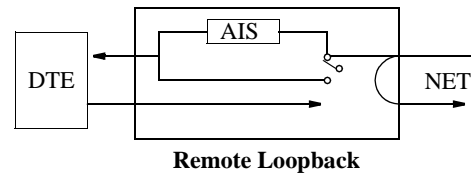

DIP switch S2 configures the unit to either generate an alarm indication signal (unframed all ones) to the DTE or to pass the received data from the network to the DTE. The unit responds to FDL loop (PLB, 000011101111111) and unloop command messages (001110001111111).

3.2.2 Test Access Jacks

Six bantam test jacks are provided for access to the T1 line on the DTE side of the CSU. Jacks allow transmit and receive toward the network, toward the DTE, or monitoring of traffic between DTE and network. These are customarily used to inject and receive T1 signals using a T1 test set.

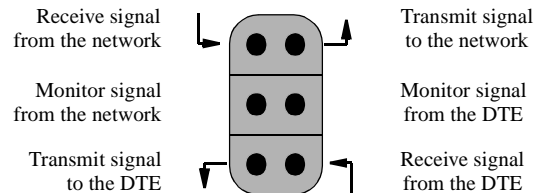

NET: The top 2 ports are used to insert into the line in both directions. They break connection to the DTE and make connection to the CSU in the direction of the network.

MON: The middle 2 ports are used for non-intrusive bridge monitoring of the line in both directions. They monitor the signals passing through the CSU (between the DTE and the network).

DTE: The bottom 2 ports are used to drop the line, to break connection to the CSU and make connection to the DTE.

3.3 Terminal Operation

When the 2010 CSU is located at the far end of a TxPORT product which has an embedded terminal interface, 2010 performance information may be accessed. The terminal interface is a firmware application program embedded inside units such as the 2000 CSU. Since the 2010 was primarily developed for placement at the far end of a 2000 CSU, the 2000 example will be used in the following para-

graphs. The reference manual supplied with the TxPORT product should be consulted for the interface system description.

The 'Performance' screen (see [Screen 3-1](#) below) displays the 24-hour performance history of the T1 circuit. The error parameters are continuously monitored. The Terminal Interface provides display of near end or far end performance data using the facility data link.

The near end unit is equipped with a dual set of performance data registers that hold line statistics for both the telco and user. Each register set provides detailed status and performance history for the network and DTE interfaces. For generic 54016 far end devices, such as the 2010, only the standard telco 24-hour performance data is displayed. The 30-day data is not available.

The fields in this screen are described as follows:

Element: Pressing the <spacebar> toggles this field for selection of either the 'NEAR' or 'FAR' unit as the source of performance data or the target of commands. 'NEAR' refers to the unit to which the terminal is connected (the 2000). 'FAR' refers to the unit at the other end of the network T1 span (the 2010).

Error Events: This field displays the running total of ESF error events for the circuit selected in 'Element' and is applicable only when 'Target' is set to [USER]. This count accumulates until it reaches 65535 or is reset by pressing <return> with the (RESET) field highlighted.

Reset Performance Registers: This field allows the element registers to be reset and may only be used when 'Target' is set to [USER]. If <return> is pressed, the following warning appears: DELETE ALL PERFORMANCE DATA? To exit this screen without performing the reset function, press <return> with (NO) selected. To proceed with the reset function, press <return> on (YES). All values for the chosen register set (NET or DTE) are then reset to zero.

The remainder of the fields in the 'Performance' screen are for display only. They are defined as follows:

Status: This field displays the selected T1 line status derived from the type (or absence) of errors in the received data. The status represents the immediate state of the received T1 signal and is not related to the alarm thresholds.

Completed Intervals: This field displays the number of 15-minute intervals in the last 24-hour period since the registers were last cleared (a 24-hour period may contain up to 96 intervals).

24 Hr. % Error Free: This field displays the percentage of error free seconds within the last 24 hours or since the event registers were last cleared. It is based only on the ES and UAS parameters.

(performance data): The main body of display data consists of error events for two different periods: The first display line shows the data accumulating for the current interval (from 0 to 900 seconds). The second line shows the

Screen 3-1 Performance

```

2000 CSU x.xx/x.xx                2010 CSU                Date MM/DD/YY
2010 CSU x.xx/x.xx                (Unit Address: xxx)    Time HH:MM:SS
-----
                                PERFORMANCE
-----
Element: [FAR ]                    Status: OK

Error Events: 65535 (RESET)        Completed Intervals: 96
                                   24 Hr.% Error Free: 98.2

                                   [STANDARD 24 HOUR]

    411                            0          0          0          2          3          3
    24 Hour                        10         0          0          2          3          0

PAGE-UP -----
Time      Interval    ES      UAS      BES      SES      LOFC      CSS
PAGE-DN -----
13:45         6         1       0       0       0         1         0
13:30         7         2       0       0       0         2         0
13:15         8         4       0       0       0         2         0

```

totals for the last 24-hour period (or the last 96 fifteen-minute intervals).

The remaining lines of this screen show the data for any of the intervals that contained errors. Interval 1 is the most recently stored interval and interval 96 is the oldest 24-hour interval. The real time of the interval beginning is shown in the first column.

If more than five errored intervals have elapsed, [PAGE-DN] appears to the left of the performance data. Pressing <return> on this field displays the next five errored intervals. [PAGE-UP] appears once [PAGE-DN] is used. Pressing <return> on [PAGE-UP] displays the previous five errored intervals. Only intervals that contained errors are displayed, which eliminates rows of zeroes. If an interval is not displayed, no errors were detected during that time period.

NOTE: The parameters shown on the 'Performance' screens are updated at 5 second intervals.

Per AT&T Technical Reference TR54016, the 'Standard 24 Hour' performance data consists of Errored Seconds (ES), Bursty Errored Seconds (BES), Severely Errored Seconds (SES), Unavailable Seconds (UAS), Loss of Frame Count (LOFC), and Controlled Slip Seconds (CSS).