

TxPORT 210 Front Panel

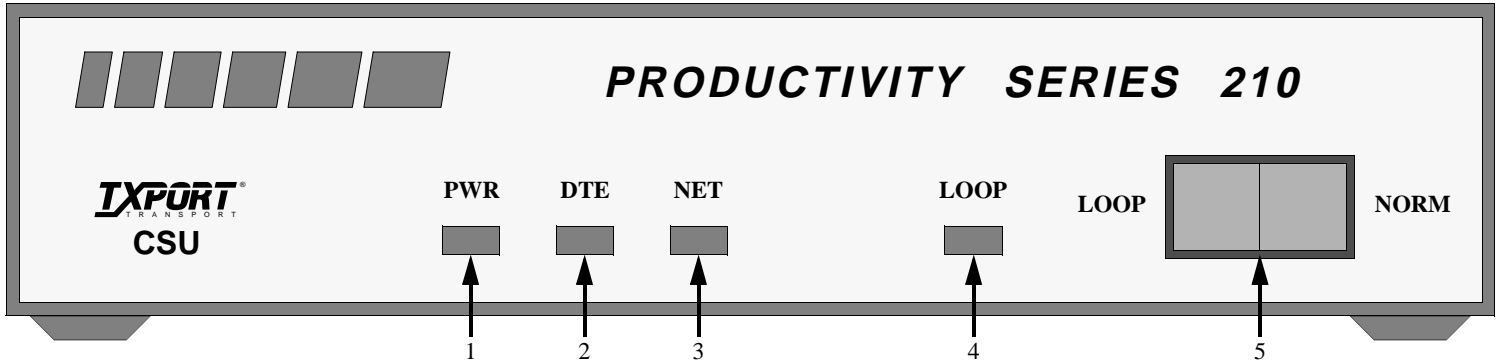

Front Panel Description

1	POWER: This green LED lights when power is applied to the unit.
2	DTE T1 Status: This red LED lights a minimum of 0.1 second if the internal alarm circuitry detects any one of the following conditions from the DTE: one or more BPVs, FBEs, CRCs, low ones density, or a loss of signal/loss of sync condition for \dot{S} 175 bit times from the network. The LED stays lit until the unit detects \dot{S} 4 pulses in 32 bit times.
3	Network T1 Status: This red LED lights a minimum of 0.1 second if the internal alarm circuitry detects any of the following conditions from the incoming T1 signal: one or more BPVs, FBEs, CRCs, or a loss of signal/loss of sync condition for \dot{S} 175 bit times from the network. The LED stays lit until the unit detects \dot{S} 4 pulses in 32 bit times.
4	Loop: This amber LED lights under the following conditions: the manual loop switch is placed in the 'LOOP' position, the unit receives an inband loop code for > 5 seconds, or the unit receives an FDL loop message (PLB or LLB). The LED does not light if the test switch is placed in the 'NORM' position or if an inband or FDL unloop code is received for >5 seconds.
5	Test Switch: This 2-position switch is used for local testing. When placed in the local loop mode (LOOP), the unit loops the signal from the customer equipment (DTE IN) back to the customer equipment (DTE OUT). It also loops the received signal from the T1 facility (NET IN) back to the T1 facility (NET OUT). When moved back to 'NORM', the local loopback is removed.

SPECIFICATIONS

Network Interface

Line Rate:	1,544 Mb/s (\pm 50 bps)
Line Framing:	Transparent
Line Code:	AMI or B8ZS
Line Impedance:	balanced 100 Ω (\pm 5%)
Input Signal:	DS1, +1 to -30 dB (ALBO)
Output Signal:	3.0 V, \pm 15%, base-peak into 100 $\frac{3}{4}$
Line Build Out:	0, -7.5, -15, and -22.5 dB attenuation
Line Protection:	1000 V lightning, fused input/output
Jitter Control:	per TR62411 and T1.403
Pulse Density:	per TR62411

Equipment Interface

Line Rate:	1,544 Mb/s (\pm 50 bps)
Line Framing:	Transparent
Line Code:	AMI or B8ZS
Line Impedance:	balanced 100 Ω (\pm 5%)
Input Signal:	DSX1 to 655 feet

Output Signal:	Selectable DSX1 signal level from 0 to 655 feet
Line Protection:	1000 V lightning, input/output

Mechanical

Mounting:	desktop or wall
Dimensions:	1.75" H, 6.8" W, 10.5" D
Weight:	2 lbs.

Industry Standards

FCC Compliance:	Part 15 Subpart B, Class A
FCC Part 68 Reg:	FXKUSA- 75742-DE-N
NRTL	UL 1459
CSA Certified:	LR62298
DOC/CSO3:	1653 5663 A
TR62411	

Environmental

Operating Temp:	0° to 50° C (32° to 122°F)
Storage Temp:	-20° to 85° C (-4° to 185°F)
Humidity:	95% max (non-condensing)

TxPORT 210 Rear Panel

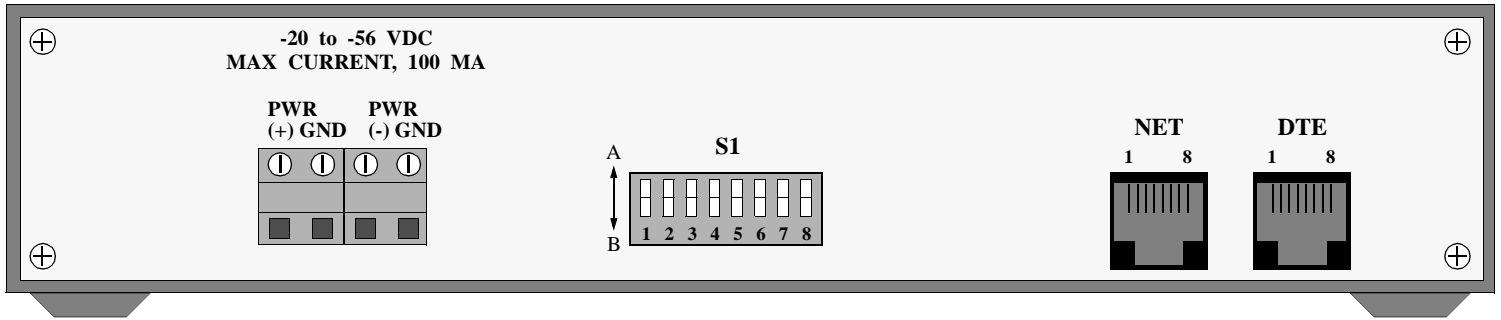

Power Connection

210 CSU connections are made on the following terminals using 20-gauge stranded (or similar) wire:

- GND (Ground)
- PWR- (-48 VDC, ± 6 V, 45 mA)
- PWR+ (Return)

NOTE: The 'A' position is the factory default for all switch settings. If a particular user configuration requires that a switch be placed in the 'B' direction, then mark this sheet for future reference.

RJ48C Interfaces

Pin	NET	DTE
1	Data In (R1)	Data Out (R)
2	Data In (T1)	Data Out (T)
3/6	Not Used	Not Used
4	Data Out (R)	Data In (R1)
5	Data Out (T)	Data In (T1)
7/8	Chassis Gnd	Chassis Gnd

Switch S1 Description

1-2	Network LBO: These 2 positions set the network line build out signal level of data transmitted towards the T1 facility. The output level is factory set at 0 dB. It may be attenuated by -7.5 dB, -15 dB, or -22.5 dB if operating conditions require a change. Refer to the diagram of Switch S1 for settings.
3-5	DTE LBO: These 3 positions set the DTE line build out transmit signal value towards the customer equipment. Refer to the diagram of Switch S1 for settings.
6	AIS Enable: Options the unit to either 'generate' unframed all ones (an Alarm Indication Signal) to the DTE during a remote loop (A) or to 'pass' the received network signal to the DTE on a remote loop (B).
8	Ones Density: Per AT&T 62411, the 'Enabled' mode allows ones density insertion after 15 successive zeros from the DTE. The 'Disabled' mode ignores density control and allows up to 175 zeros to pass towards the network before a loss of signal is declared.

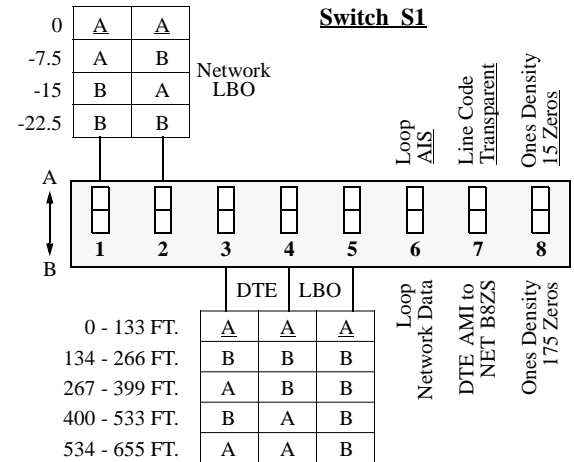

Loopbacks

The unit can be looped remotely by generating towards it a standard CSU line loopback code (00001 repeating for 5 seconds, framed or unframed). Once looped, the received signal from the T1 facility (NET IN) is regenerated and transmitted back to the T1 facility (NET OUT). The unit is unlooped remotely by generating towards it a standard CSU line unloop code (001 repeating for 5 seconds, framed or unframed).

DIP switch S1-6 configures the unit to either generate an unframed all ones (AIS) signal to the DTE or to pass the received data from the network to the DTE.

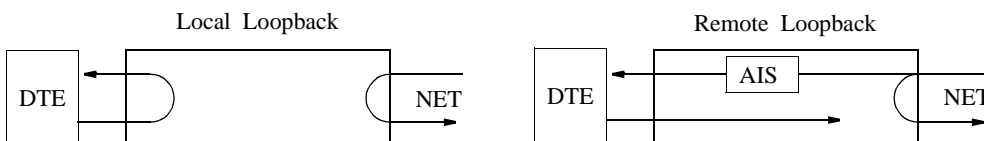

TxPORT Customer Service
127 Jetplex Circle
Madison, Alabama 35758

Customer Service Returns:
800-926-0085, ext. 227

Product Technical Support
(8 a.m. to 5 p.m.)
800-285-2755 or
205-772-3770, ext. 255

After Hours Hot Line:
205-551-7538