

TxPORT 300 Front Panel

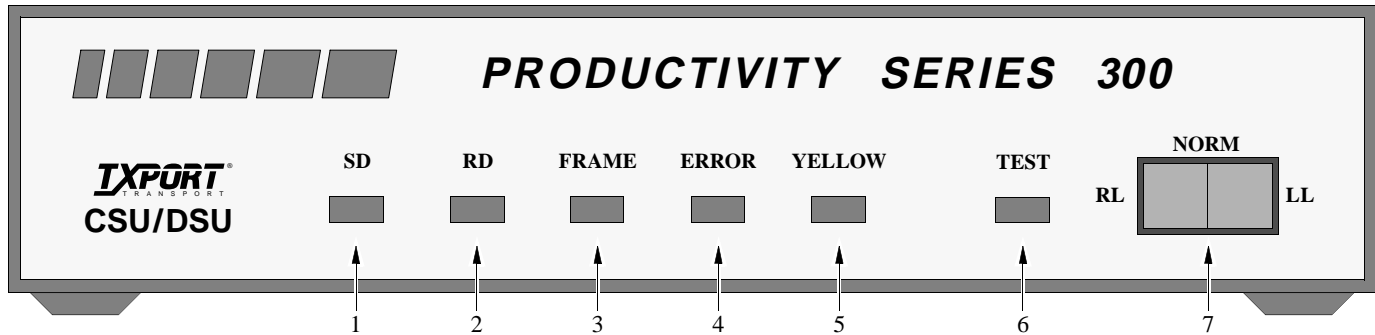

Front Panel Description

1	Send Data: This green LED lights when the SD data lead is a mark and is off when the lead is a space. Therefore, the LED will vary from full intensity to off depending on the relative number of marks and spaces.
2	Receive Data: This green LED lights when the RD data lead is a mark and is off when the lead is a space. Therefore, the LED will vary from full intensity to off depending on the relative number of marks and spaces.
3	Frame: This green LED lights when the unit is in frame synchronization with the T1 line.
4	Error: This red LED lights if the internal alarm circuitry detects any of the following conditions from the incoming T1 signal: BPVs, FBEs, CRCs, loss of signal/loss of sync, or more than 175 zeros.
5	Yellow: This red LED lights if the internal alarm circuitry detects a remote (yellow) alarm signal from the far end terminal equipment. This occurs if the far end terminal is out of sync with the T1 signal from the network.
6	Test: This amber LED remains lit if the unit is in a test mode, either by manually depressing the loop switch or by receipt of a test command from the facility.
7	Test Switch: This 3-position switch is used as follows: Depressing the switch to the 'LL' position places the unit in a local loop mode. Data from the DTE is looped back to the DTE and is also transmitted to the network (the data from the network is open). Depressing the switch to the 'RL' position initiates an automated V.54 remote loop and BERT sequence of assigned data channels. The 'TEST' LED will be green if the test is successful (the far end unit loops and returns the data error free with the V.54 code). If errors are detected, the 'TEST' LED will be red.

SPECIFICATIONS

Network Interface

Line Rate:	1.544 Mbps (± 50 bps)
Line Framing:	D4 or ESF
Line Code:	AMI or B8ZS
Line Impedance:	balanced 100 Ω (± 5%)
Input Signal:	DS1, +1 to -27 dB (ALBO)
Output Signal:	3.0 V (±15%) base-peak into 100 Ω
Line Build Out:	0, -7.5, -15, and -22.5 dB attenuation
Line Protection:	1000 V lightning, input/output
Jitter Control:	per TR62411 and T1.403
Pulse Density:	per TR62411

Industry Standards

FCC:	Part 15 Subpart B, Class A
UL:	1459 2 nd Edition
CSA:	C22.2 No. 225-M90
IC:	CSO3 Issue 8
ANSI T1.403:	1989
TR54016:	September 1989
TR54019:	April 1988
TR62411:	December 1990

Power

AC Power:	115 VAC (± 10%), 150 mA max, 20 Watts, 73 BTU max.
Connection:	5-foot power cord

Mechanical

Mounting:	Desktop, wall, or vertical rack
Dimensions:	1.75 inches (4.45 cm) high 6.8 inches (17.27 cm) wide 10.5 inches (26.67 cm) deep 2 pounds (0.91 kg)

Environmental

Operating Temp:	32° to 122°F (0° to 50° C)
Storage Temp:	-4° to 185°F (-20° to 85° C)
Humidity:	95% max (non-condensing)

V.35 Interface

Data Rate:	Synch, N x 56 or N x 64 kbps
Clocking:	Internal or external

TxPORT 300 Rear Panel

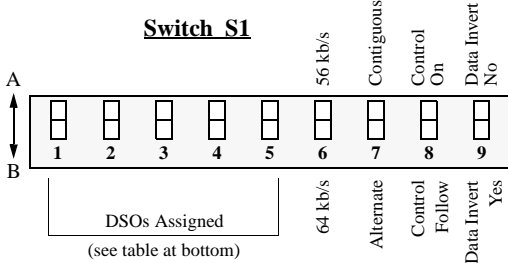
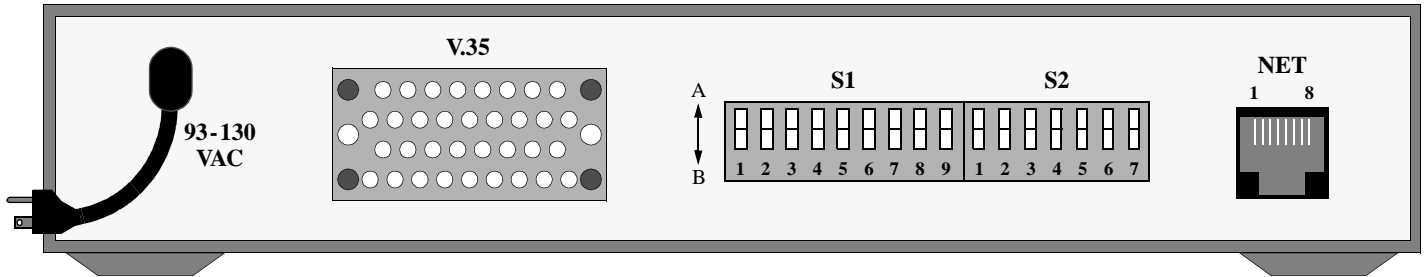

Switch S1 Description

1 - 5	DSOs Assigned: These five positions select the bit rate and the number of DSOs assigned to the channel (refer to the table below).
6	Rate Multiplier: Sets the multiplier for the input timing (refer to the table below). The unit operates at any data rate that is a multiple of 56 or 64 kb/s.
7	Channel Assignment: The Contiguous mode assigns the channels as a block beginning at DSO channel 1. If 'Alternate' is selected, channel assignments are made with an idle channel following each data channel.
8	Control Lines: 'On' permanently sets the CTS, DSR, and CD leads to ON. With 'Follow', the DSR lead follows T1 sync, the CTS lead follows RTS, and the CD lead follows the density status of the incoming T1 signal (\$175 zeros = CD OFF). The TM line goes high when the unit is in a local or remote test mode.
9	Data Invert: Determines whether the data bits are inverted.

Switch S2 Description

1 - 2	Timing Source: Selects the source of unit clocking (refer to the Switch S2 table).
3	ESF Mode: 54016 mode - unit responds only to 54016 CSU messages. T1.403 mode - unit responds to ANSI loop/unloop commands and generates a PRM every second, but will not respond to 54016 messages.
4	Network Framing: In the ESF mode, the units can be configured for either the T1.403 or 54016 mode. In the 54016 mode, the unit responds to all 54016 messages. In the T1.403 mode, the unit generates a PRM (performance report message) once every second and responds to T1.403 messages only.
5	Network Coding: Sets the network line code format.
6 - 7	Network LBO: Set the network signal level of data transmitted towards the T1 facility (refer to table).

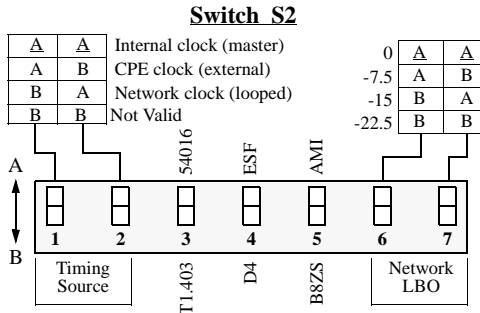

Network Pinout

1	Data In (R1)
2	Data In (T1)
3/6	Not Used
4	Data Out (R)
5	Data Out (T)
7/8	Chassis Gnd

NOTE: The 'A' position is the factory default for all switch settings. If a particular user configuration requires that a switch be placed in the 'B' direction, then mark this sheet for future reference.

V.35 Interface

Circuit	Pin #	Signal Name	DCE
101	A	Frame Ground	Ground
102	B	Signal Ground	Ground
103	P/S	Transmit Data	In
104	R/T	Receive Data	Out
105	C	Request To Send	In
106	D	Clear To Send	Out
107	E	Data Set Ready	Out
109	F	Data Carrier Detect	Out
113	U/W	External Transmit Clock	In
114	Y/AA	Transmit Clock	Out
115	V/X	Receive Clock	Out
142	K	Test Mode	Out

1	B	B	B	B	B	56 kb	64 kb
2	B	A	B	B	B	112	128
3	A	A	B	B	B	168	192
4	B	B	A	B	B	224	256
5	A	B	A	B	B	280	320
6	B	A	A	B	B	336	384
7	A	A	A	B	B	392	448
8	B	B	B	A	B	448	512
9	A	B	B	A	B	504	576
10	B	A	B	A	B	560	640
11	A	A	B	A	B	616	704
12	B	B	A	A	B	672	768
13	A	B	A	A	B	728	832
14	B	A	A	A	B	784	896
15	A	A	A	A	B	840	960
16	B	B	B	B	A	896	1024
17	A	B	B	B	A	952	1088
18	B	A	B	B	A	1008	1152
19	A	A	B	B	A	1064	1216
20	B	B	A	B	A	1120	1280
21	A	B	A	B	A	1176	1344
22	B	A	A	B	A	1232	1408
23	A	A	A	B	A	1288	1472
24	A	A	A	A	A	1344	1536

Loops

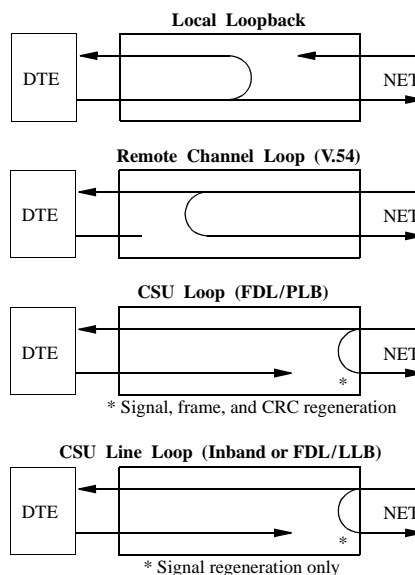

127 Jetplex Circle
Madison, Alabama 35758

Sales and Marketing

800-926-0085
205-772-3770
info@txport.com

RMA/ Returns

800-926-0085, ext. 2282

Technical Support

800-285-2755
205-772-3770
support@txport.com