

# **Verilink DIU 2140 User Manual**

*June 1998*

*P/N 880-501614-001-A*

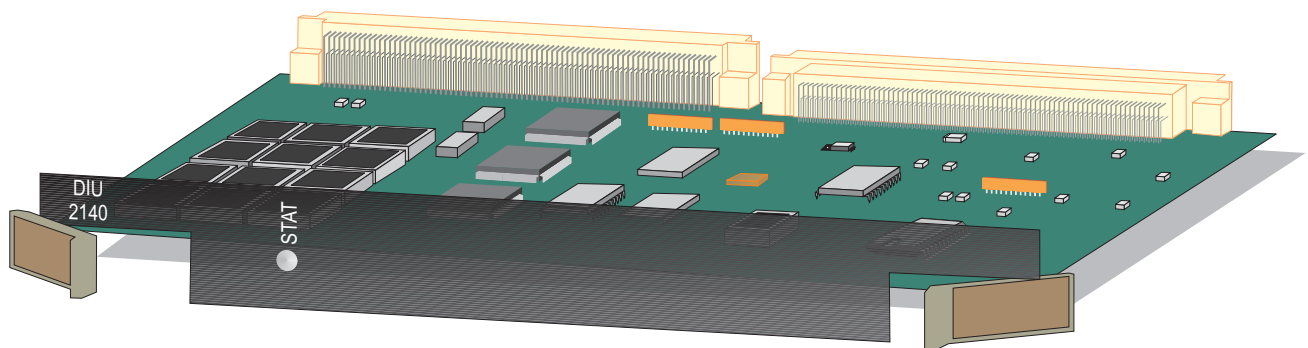

## Copyright Notice

Copyright © 1998 Verilink Corporation. All rights reserved.

VERILINK CORPORATION DISTRIBUTES THIS REFERENCE “AS IS” WITHOUT WARRANTY OF ANY KIND, EITHER LIMITED, EXPRESSED, OR IMPLIED.

Verilink Corporation reserves the right to revise this publication from time to time without notice. Some states or jurisdictions do not allow disclaimer of express or implied warranties in certain transactions; therefore, this statement may not apply to you.

The following are trademarks or registered trademarks of Verilink Corporation: Access System 2000, Access Manager 2000, Advanced Programmable Architecture, and Craft Interface.

Your right to copy software and this manual is limited by copyright law. Duplication of this reference, or any part thereof, without prior written authorization from Verilink Corporation is prohibited by law and constitutes a punishable violation of the law.

The following are copyright/trademarks of their respective companies or organizations: Microsoft Windows, Microsoft Corporation

## Customer Service and Sales Information

To receive more detailed information on service options and pricing, contact Customer Services at 1-800-VERILINK (1-800-837-4546). Or access our FAX on Demand System for our latest customer service brochure at 1-800-957-LINK (1-800-957-5465).

## FCC Statement (AS2000 Equipment)

Federal Communications Commission (FCC) Rules require that you be notified of the following:

This equipment has been tested and found to comply within the limits for a Class A digital device pursuant to Part 15 of the FCC rules. These limits are designed to provide protection against harmful interference in a residential installation.

This equipment generates, uses, and can radiate radio frequency energy and, if not installed and used in accordance with the instructions, may cause harmful interference to radio communications. However, there is no guarantee that interference will not occur in a particular installation. If this equipment does cause harmful interference to radio or television reception—which can be determined by turning the equipment off and on—try to correct the interference by one or more of the following measures:

- Reorient or relocate the receiving antenna.
- Increase the separation between the equipment and receiver.
- Connect the equipment into an outlet on a circuit different from that to which the receiver is connected.
- Consult the dealer or an experienced radio/TV technician for help.

Per FCC Part 68 requirements, the customer is required to notify the Telephone Company before disconnecting any CSU from the network interface.

The following references apply to this system:

- The FCC registration number for Access System 2000 is GICUSA-18804-DE-N.
- The USOC jack required is USOC RJ48C/M/X
- The Facility Interface Code for Digital Service is 04DU9-1KN/ISN/ISN/12N.
- The Service Order Code for Digital Service is 6.0N.

## Warning

---

**NOTE:** The battery referred to in the following notices is contained **inside** the clock chip.

---

## English

## DANGER!

**The battery could explode if it is incorrectly replaced! Replace only with the same or equivalent type recommended by the manufacturer. Dispose of used batteries according to the manufacturer's instructions.**

**DANGER!**

To avoid electrical shock in case of failure, the power supply must be installed by a professional installer. The terminal labeled with the ground symbol ( $\text{—}\text{—}$ ) on the power supply must be connected to a permanent earth ground.

**CAUTION!**

Interconnecting circuits must comply with the requirements of EN60950:1992/A2:1933 Section 6.2 for telecommunications network voltages (TNV) circuits.

---

**Français**

**ATTENTION!**

Une explosion peut se produire si la batterie est remplacée d'une façon incorrecte! Remplacez-la seulement avec le même modèle de batterie ou un modèle équivalent selon les recommandations de manufacture. Disposez de les batteries usées selon les instructions de manufacture.

**ATTENTION!**

Pour éviter un choc électrique en cas de succès, la provision de pouvoir devra être installée par un installateur professionnel. La terminal de la provision de pouvoir, marquée du symbole de terre, ( $\text{—}\text{—}$ ) doit être connecté à un point de terre électrique permanent.

**ATTENTION!**

Les circuits doivent être interconnectés de manière à ce que l'équipement continue à être en agrément avec "EN60950:1992/A2:1933, Section 6.2, pour les circuits de voltage de liaisons d'échanges (réseau) par les télécommunications (TNV)," après les connexions de circuits.

---

**Españole**

**PELIGRO!**

La batería puede explotar si se reemplaza incorrectamente. Reemplace la batería con el mismo tipo de batería ó una equivalente recomendada por el fabricante. Disponga de las baterías de acuerdo a las instrucciones del fabricante.

**PELIGRO!**

Para evitar contacto con circuitos que electrocutan, la fuente de alimentación debe ser instalada por un técnico profesional. La terminal de la fuente de alimentación marcada con el símbolo de tierra ( $\text{—}\text{—}$ ) debe ser conectada a un punto de tierra permanente.

**CIRCUITOS A INTERCONECTARSE**

Circuitos que se interconectan a la red de telecomunicaciones deben hacerse de tal manera que cumplan con los requisitos estipulados en las especificaciones "EN60950:1992/A2:1933, Sección 6.2, para los voltajes de circuitos interconectados a la Red de Telecomunicaciones (TNV)," después de terminar las conexiones entre los circuitos.

---

**Deutsch**

**VORSICHT!**

Explosionsgefahr bei unsachgemäßem Ersetzen der Batterie! Batterie gleichen Typs und gleicher Qualität benutzen, wie vom Hersteller empfohlen. Entsorgung der Batterie nach Anweisung des Herstellers!

**VORSICHT, GEFAHR!**

Um keinen Schlag zu erhalten beim Versagen der elektrischen Anlage, muss der Stromanschluss von einem Elektriker vorgenommen werden. Der elektrische Pol, versehen mit dem Erdsymbol ( $\text{—}\text{—}$ ) muss am Stromanschluss permanent geerdet sein.

**VORSICHT!**

Schaltungen, die in den Geräten zusammengeschaltet sind, müssen weiterhin den Vorschriften EN60950:1992/A2:1933, Absatz 6.2 für Telecommunications Netz Spannung (TNV) Schaltkreise entsprechen.

---

## **Safety Precautions**

When handling this equipment, follow these basic safety precautions to reduce the risk of electric shock and injury:

- Follow all warnings and instructions marked on the product and in the manual.
- Unplug the hardware from the wall outlet before cleaning. Do not use liquid cleaners or aerosol cleaners. Use a slightly damp cloth for cleaning.
- Do not place this product on an unstable cart, stand, or table. It may fall, causing serious damage to the product.
- Slots and openings in the shelves are provided for ventilation to protect them from overheating. These openings must not be blocked or covered. Never place this product near a radiator or heat register.
- This product should be operated only from the type of power source indicated on the marking label and manual. If you are unsure of the type of power supply you are using, consult your dealer or local power company.
- Do not allow anything to rest on the power cord. Do not locate this product where the cord will interfere with the free movement of people.
- Do not overload wall outlets and extension cords, as this can result in fire or electric shock.
- Never push objects of any kind into the shelves. They may touch dangerous voltage points or short out parts that could result in fire or electric shock. Never spill liquid of any kind on this equipment.
- Unplug the equipment from the wall outlet and refer servicing to qualified service personnel under the following conditions:
  - a. When the power supply cord or plug is damaged or frayed.
  - b. If liquid has been spilled into the product.
  - c. If the product has been exposed to rain or water.
  - d. If the product has been dropped or if the cabinet has been damaged.

## **Customer Service**

Verilink offers the following services:

- System Engineers at our major sales offices to assist you in the design and planning of your network.
- Technical Assistance Services to provide you with telephone support for installation, maintenance, and administrative support for contracts and leasing.
- Training Services to assist you in better understanding the network and equipment.

## **Publications Staff**

This manual was written and illustrated by David Gardner. Contributing Writers and Editors: Dave Fradelis, Marie Metivier, Steve Rider, and Barbara Termaat.

---

## Table of Contents

### DIU 2140

---

DIU 2140 SRDM Overview .....	1-1
Scope .....	1-1
Product Description .....	1-1
DIU 2140 .....	1-1
Related Verilink Documents .....	1-2
Management Programs .....	1-2
Management Modules .....	1-2
DIU 2140 Front Module .....	1-3
Data Interface Module .....	1-3
DIM 2232 .....	1-3
CSU Interfaces .....	1-4
DIU Data Buses .....	1-4
Transmit Side Functions .....	1-4
Test Signal Generator .....	1-4
Receive Side Functions .....	1-4
Specifications .....	1-5
DIU 2140 Quick Set-up .....	2-1
Installation .....	2-1
Configuring the DIU 2140 .....	2-2
Configuration / Diagnostic Menu .....	2-3
Select CSU .....	2-4
Select DSO Channel .....	2-4
DDSU Mode .....	2-4
Port Selection .....	2-4
Loopbacks .....	2-4
DIU 2140 Configuration .....	3-1
Configuration/Diagnostics .....	3-1
Configuration / Diagnostic Menu .....	3-2
Diagnostics .....	4-1
LED Indicator .....	4-1
STAT LED .....	4-1
Diagnostics .....	4-2
Data Channel Loopbacks .....	4-2



## DIU 2140 SRDM Overview

This manual describes the DIU 2140 Subrate Data Multiplexer (SRDM) data service unit and its associated rear connector module—components of Verilink’s Access System 2000 (AS2000) platform.

### Scope

This manual assumes you are familiar with standard AS2000 products. Where appropriate, the text refers you to a specific AS2000 manual for greater detail.

### Product Description

The DIU 2140 subrate data multiplexer is an RS-232 five-channel time division multiplexer and data service unit (DSU) that provides low-speed data transmission from multiple subrate data applications over the network.

#### DIU 2140

DIU 2140’s five data ports operate at rates of 300 bit/s to 19.2 kbit/s. The DIU places these signals on a user-assigned DS0 channel timeslot of the DS1 signal. It then sends the channelized data to a channel service unit (CSU) (NCC 2020, SCC 2020, TAC 2010, or—with an NCM 2000—a DIDCSU 2912), where the data is multiplexed onto a T1 line for network transmission. In the opposite direction of transmission, the DIU 2140 receives the incoming network signal from the CSU and passes the data to the data terminating equipment (DTE).

**Figure 1-1 Typical DIU 2140 Application**

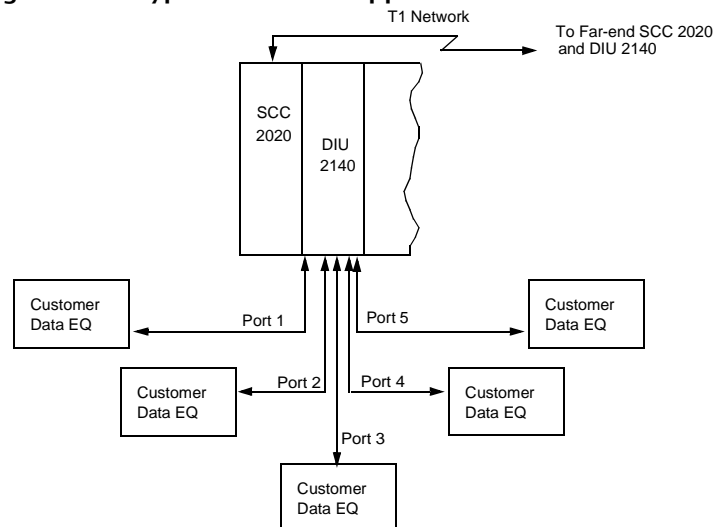

Up to twelve DIUs and one NCC 2020, SCC 2020, or TAC 2010 provide carrier network access and T1 transmission for low-speed data applications.

---

## Related Verilink Documents

Refer to the following related Verilink manuals:

- *AS2000: The Basics*—for information on physical installation of shelves, modules, and power supplies.

---

## Management Programs

- *Node Manager for Windows 95 User Manual*—documents the Verilink network management program designed to operate under Windows 95 or Windows NT.
- *Access Manager 2000 User Manual*—documents the Verilink network management program designed to operate under Windows 3.1.

---

## Management Modules

The DIU 2140 is managed by one of five Verilink controller modules:

- NCM 2000—an SNMP node controller. It does not contain any type of T1 CSU. See the *NCM 2000 User Manual*.
- SCC 2020—a TAC 2010 T1 CSU with the addition of an SNMP node controller function. See the *SCC 2020 User Manual*.
- SCC 2130—a TAC 2130 T1 IDCSU (Integrated T1 CSU/DSU) with the addition of an SNMP node controller function. See the *SCC 2140 User Manual*.
- NCC 2020—a TAC 2010 T1 CSU with the addition of a node controller function. See the *NCC 2020 User Manual*.
- NCC 2130—a TAC 2130 T1 IDCSU (Integrated T1 CSU/DSU) with the addition of a node controller function. See the *NCC 2140 User Manual*.

With these controllers you can configure the DIU 2140 through an ASCII terminal port (Local or Craft interface). Depending on the controller module, you can also manage the DIU 2140 using one of two Verilink management programs, or an industry standard SNMP manager. Table 1-1 lists the ways to access the DIU 2140 with the various controllers and programs.

Table 1-1 Module Access Methods

Node Controller Module	Craft Interface	Node Management Program
NCM 2000	Use port labelled LOCAL.	Verilink Node Manager or any SNMP manager.
NCC 2020 NCC 2140	Use port labelled CRAFT.	Verilink Access Manager or Verilink Node Manager.
SCC 2020 SCC 2140	Use port labelled CRAFT.	Verilink Node Manager or any SNMP manager.

## DIU 2140 Front Module

The DIU 2140 front module (P/N 310-010414-002) has a status LED to aid in troubleshooting ([Figure 1-2](#)).

Figure 1-2 DIU 2140 Front Panel



## Data Interface Module

A Data Interface Module (DIM)—or rear connector module—connects the DIU 2140 to the data equipment. The DIM mates with the associated DIU 2140.

### DIM 2232

DIM 2232 (P/N 311-010404-001) provides:

- Dual (2) RS-232 DB-25 connectors and one (1) DB-37 connector for connecting Data Terminal Equipment (DTE). The DB-25 connectors are for Data Ports 1 and 2, and the DB-37 connector is for Data Ports 3, 4, and 5.

Figure 1-3 DIM 2232

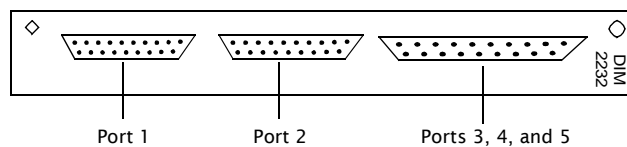

**NOTE:** A pigtail connector is required for connecting 3 RS-232 DB-25 connectors to the DB-37 port.

## CSU Interfaces

The DIU 2140 is a Data Service Unit (DSU) that must interface with a Channel Service Unit (CSU) for access to the network.

For a typical CSU/DSU configuration with multiple DIUs, up to 12 DIU 2140s can be connected to an NCC 2020, SCC 2020, or TAC 2010 to accommodate up to 60 data ports. Each port operates at 9600 bit/s and each DIU 2140 requires one DS0 channel on the T1 network.

---

## DIU Data Buses

Three separate data buses (A, B, and C) transmit data between the DIUs and the associated NCCs, SCCs, or TACs. These buses are located on the system shelf midplane, and can be extended from shelf to shelf with data-bus extension cables. In T1 multiplexer (CSU/DSU) mode, one data bus is assigned to each CSU-DIU pair. In drop-and-insert, data bus "A" is assigned to each CSU-DIU pair. A second bus is required if the DIUs and CSU are timed from an external clock source, or timed from the data equipment connected to a DIU data port.

When transmitting toward the network, the data bus sends the output data from each DIU to the CSU. It sends clocking and framing information from the CSU to the DIUs. The transmit clock synchronizes the DIU transmit side circuits to the CSU.

When receiving signals from the network, the data bus sends the data from the CSU to the DIU. It provides receive clock and framing information to the DIU, synchronizing the DIU's receiver to the CSU.

---

## Transmit Side Functions

The DIU transmit data ports receive data from the customer equipment (DTE). The data from all ports is multiplexed and sent to the associated CSU through the assigned data bus for placement on a designated T1 DS0 timeslot.

### Test Signal Generator

When activated, the test code generator substitutes a four-bit pseudorandom bit sequence (PRBS) signal with a pattern of varying ones and zeros for the normal data on the selected channel. This signal is used for end-to-end circuit bit error testing.

---

## Receive Side Functions

The receive side extracts the incoming data from the associated CSU, demultiplexes the data, and sends it to the customer data equipment.

## Specifications

Specifications of the DIU 2140 and associated DIM are given below.

**Table 1-2 DIU 2140 and DIM Specifications**

<b>Data Equipment Interface</b>	<ul style="list-style-type: none"> <li>· <b>I/O Ports:</b> Five synchronous/asynchronous</li> <li>· <b>Interfaces:</b> ITU-T RS-232; DCE to DTE</li> <li>· <b>RS-232 Signal Levels:</b> 0.55V <math>\pm</math>20% (balanced signals) or +5V to +15V (unbalanced)</li> <li>· <b>Channelization:</b> D4, in accordance with AT&amp;T TR-62411</li> <li>· <b>Loopbacks:</b> Local on each data channel</li> <li>· <b>Backup Battery Life:</b> Battery has power for three months without external power.</li> </ul>
<b>Power Requirements</b>	<ul style="list-style-type: none"> <li>· <b>Current Drain:</b> 0.5A (nominal) at +5 V<sub>dc</sub></li> <li>· <b>Power Dissipation:</b> 2.5W (8.4 BTU), nominal</li> </ul>
<b>Environmental</b>	<ul style="list-style-type: none"> <li>· <b>Operating Temperature:</b> 32° F (0° C) to 122° F (50° C)</li> <li>· <b>Humidity:</b> 95%, non-condensing</li> </ul>



## DIU 2140 Quick Set-up

This section details a quick, step-by-step procedure for configuring the DIU 2140. For this quick configuration guide, the following assumptions are made:

- That you have a DIU 2140 DSU and a single SCC 2020 module in a Multi-line shelf.
- That you are dividing the bandwidth of a T1 DS0 evenly between the five data ports of the DIU 2140.
- That you are using the SCC 2020 controller module in slot 1 of shelf 1.

Figure 2-1 Example Configuration

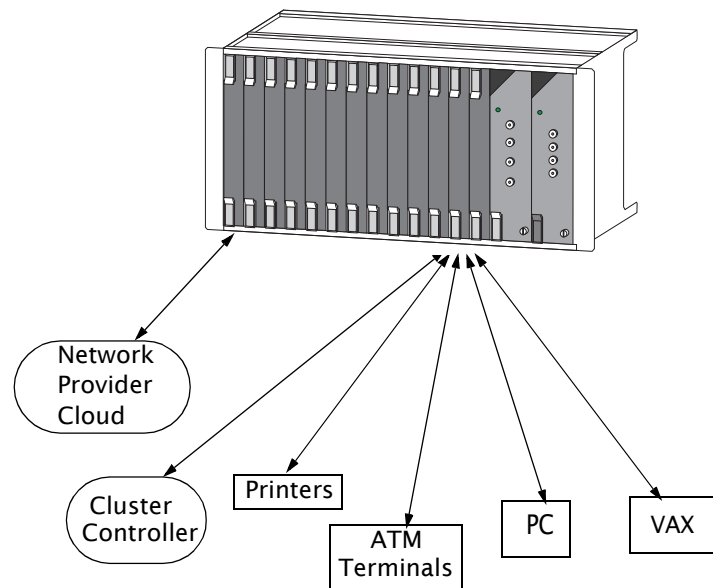

This procedure may not match your configuration exactly. Use this chapter as a guide to the process of installing your equipment. Chapter 3 provides complete details on configuration covering all selectable options.

---

## Installation

Do the following before installing the DIU:

- Install all associated Access System 2000 shelves and power supplies, as outlined in the *AS2000: The Basics* manual.
- Install and test the controller module/CSU. Ensure the CSU is configured to operate with the DIU.

The following CSU configuration options are set before use with a DIU:

- DIU Data Bus Assignment
- DIU Timing Mode

The DIU 2140 is always a DCE device. The external customer data equipment must be DTE.

Install a DIU 2140 and DIM in any shelf/slot, except Slot 1 in Shelf 1 of each node—this slot is reserved for the node controller. Then, configure the DIU module before connecting the DIM to the customer data equipment (DTE).

## Configuring the DIU 2140

For this example, an SCC 2020 is used with a DIU 2140 module in the far right side (slot 13) of a multi-line shelf. The SCC 2020 connects to the T1 circuit, providing CSU functionality. The DIU 2140 has five synchronous or asynchronous serial interfaces to connect the data terminal equipment (DTE) and provides DSU functions.

Before configuring the module, select it using the Shelf/Slot command, **S**, from the controller module's **Main Menu** (Figure 2-2). When you first log in, the default selected is the controller module (in this case, the SCC in shelf 1, slot 1).

Figure 2-2 SCC 2020 Main Menu

```

-- VERILINK SCC NODE CONTROLLER at[1,1]: FW Rev 1.97, July 16, 1997 --
FLASH BANK: B      Serial Number: 00465058
Ethernet Address: A0:6A:00:07:18:A2:
Slip Local IP Address: 0.0.0.0, Subnet Mask: 255.255.255.0
Ethernet Local IP Address: 192.94.46.68, Subnet Mask: 255.255.255.0
SITE NAME: SCC      NODE ID: 3
                                <- SLOT ->
SHELF   1    2    3    4    5    6    7    8    9    10   11   12   13
1        C    B                I    I    C    D    C    C    F    L  [R]
2
3
4
KEY: C = CSU, D = DIU, F = DIU/DDS, R = SRD, I = IDCSU, T = TU, A = APS,
     B = DIU/DBU, S = SMDS, L = HLM
S) shelf/slot                D) diagnostics
N) near element              O) node administration
F) far element                M) monitor alarms (ON)
C) configuration              A) view alarm buffer
P) performance                X) log off

```

The **S) shelf/slot** command is used to navigate between modules. Type "S" and press ENTER. The prompt for selecting another module displays:

**Enter shelf,slot >**

For this example, the node has only one shelf (shelf 1) and the DIU 2140 is in slot 13 of that shelf. Type "1,13" and press ENTER.

The prompt line displays:

**[1,13] DIU 2140 (UPDATE) >**

This indicates that the DIU 2140 has been selected. Type "C" and press ENTER to display the DIU 2140 **Configuration Menu**.

---

***NOTE:** The word UPDATE in the command line prompt indicates that information has changed since the screen was last refreshed. Refresh the screen with current information by pressing ENTER.*

---

## Configuration / Diagnostic Menu

The DIU 2140 module tries to communicate with a CSU module in Shelf 0, Slot 0 (the default value for CSU assignment in a new DIU 2140). An address of Shelf 0, Slot 0 is not a valid address. Modules are shipped with this default so they can be added to a shelf without conflict. An error message displays:

**No response from csu[ 0,0 ]**

The error message indicates the DIU 2140 is new and is not yet assigned to any CSU. Ignore this error message.

The DIU 2140 **Configuration Menu** displays.

**Figure 2-3 Initial DIU 2140 Configuration/Diagnostic Menu (from an SCC 2020)**

```

--- DIU 2140 CONFIGURATION MENU ---
      REST  RESTORE SAVED CONFIG TO SRD
      SAVE  SAVE SRD CONFIG TO CONTROLLER
0-0    CSU   SELECT CSU
--     CHNL  SELECT DS0 CHANNEL
M1     M1-M5 DDSU  MODE
              (DS0B, 19.2+3S, DS0A, 19.2+FEC, 19.2+19.2+S)
1      PORT  SELECT  DDSU  PORT (1-5)
0      B1-B6 BAUD RATE FOR SELECTED PORT
              (300, 600, 1200, 2400, 4800, 9600)
Y      SYNC  SYNCHRONOUS TRANSMISSION
N      ASYNC ASYNCHRONOUS TRANSMISSION
              --- DIU 2140 DIAGNOSTIC MENU ---
      SNE   SET NEAR END LOOPBACK
      CNE   CLEAR NEAR END LOOPBACK
      X     EXIT MENU

[1,13] DIU 2140 >
    
```

**Select CSU** The first task is to set the CSU address the DIU 2140 will be using. Type “**CSU**” and then press ENTER. The prompt will display:

```
enter shelf >
```

Type the shelf number, then press ENTER. The prompt will display:

```
enter slot >
```

Type the CSU slot number (in this case, **10**), then press ENTER. The prompt will display:

```
[1,13] DIU 2140 (UPDATE) >
```

Press ENTER to refresh the screen and set the parameter.

**Select DS0 Channel** The DIU 2140 can only use one DS0 timeslot. Select this CSU timeslot using the **CHNL** command. Type “**CHNL**” and then press ENTER. The prompt will display:

```
ENTER DS0 CHANNEL:
```

In this case, type “**24**”, then press ENTER. The **UPDATE** prompt will again display. Press ENTER again to refresh the screen with the new information.

**DDSU Mode** To define how many data ports of the DIU 2140 are used and the rates at which each port operates, use one of the DDSU Mode commands. The legend under the command title on the **Configuration Menu** briefly describes each of the options available. For this example, type “**M1**” and press ENTER. Then press ENTER again to refresh the screen with the new information.

This will activate all five ports on the DIU 2140 and they will operate at a substrate of 0.3 and 9.6 kbit/s, multiplexed into a DDS-like DS0B signal.

**Port Selection** This command is for selecting each individual DDSU port (1 through 5) for setting baud rates, setting synchronous / asynchronous transmission, and setting and clearing loopbacks. In most cases, the port will be set for synchronous transmission.

**Loopbacks** For localized troubleshooting, the loopback commands SNE and CNE enable you to Set Near End Loopbacks and Clear Near End Loopbacks on each of the ports.

When the CSU has been connected for fifteen minutes, valid performance statistics are available under the controller module’s **Performance Monitoring Menu**. See the controller module user manual for more information.

Use the controller module’s **Diagnostics Menu** for additional troubleshooting.

# Chapter 3

## DIU 2140 Configuration

Before configuring a DIU 2140, verify:

- A data bus is assigned to the CSU.
- The DIU timing mode is selected on the associated CSU.

### Configuration/Diagnostics

The letter **R** on the Shelf/Slot map of the **Main Menu** of the controller module represents a DIU 2140 Substrate Data Module (SRDM) DSU. The DIU 2140 is used in conjunction with a CSU module—NCC 2020, SCC 2020, TAC 2010; or—with an NCM 2000—a DIDCSU 2912. Each DIU 2140 supports one to five RS-232 data ports.

To configure the DIU 2140, first select it using the Shelf/Slot command, **S**, from the controller module (in this case, the SCC in shelf 1, slot 1) **Main Menu** (Figure 3-1).

Figure 3-1 SCC 2020 Main Menu

```
-- VERILINK SCC NODE CONTROLLER at[1,1]: FW Rev 1.97, July 16, 1997 --
FLASH BANK: B      Serial Number: 00465058
Ethernet Address: A0:6A:00:07:18:A2:
Slip Local IP Address: 0.0.0.0, Subnet Mask: 255.255.255.0
Ethernet Local IP Address: 192.94.46.83, Subnet Mask: 255.255.255.0
SITE NAME: SCC      NODE ID: 3

                                <- SLOT ->
SHELF    1    2    3    4    5    6    7    8    9    10   11   12   13
1         C    B                    I    I    C    D    C    C    F    L    [R]
2
3
4
KEY: C = CSU, D = DIU, F = DIU/DDS, R = SRD, I = IDCSU, T = TU, A = APS,
     B = DIU/DBU, S = SMDS, L = HLM
S) shelf/slot                D) diagnostics
N) near element              O) node administration
F) far element               M) monitor alarms (ON)
C) configuration             A) view alarm buffer
P) performance               X) log off
```

The **S) shelf/slot** command is used to navigate between modules. Type “S” and press ENTER. The prompt for selecting another module displays:

```
Enter shelf,slot >
```

For this example the node has only one shelf (shelf 1) and the DIU 2140 is in slot 13 of that shelf. Type “1,13” and press ENTER.



Command	Description	Options
M1—M5	<p>DDSU Mode—This command selects the DIU 2140 ports and multiplexing mode used to put the RS-232 datastreams together in the single DS0 of the T1 bandwidth. Select a mode by entering the letter M and a digit from 1 to 5.</p> <p>M1—DS0B format per AT&amp;T TR 54075. Five ports are active and each may be set to any data rate between 300 and 9600 bit/s.</p> <p>M2—Port 1 at 19,200 BPS and three ports at any rate between 300 and 9600 bit/s. Port 5 is inactive.</p> <p>M3—DS0A as defined in AT&amp;T TR 54075. Port 1 is the only active port and supports any data rate from 300 to 9600 bit/s.</p> <p>M4—Port 1 only at 19,200 with forward error correction (FEC) per DS0A. Ports 2 through 5 are inactive.</p> <p>M5—Ports 1 and 2 at 19,200 bit/s and port 3 at any rate from 300 to 9600 bit/s. Ports 4 and 5 are inactive.</p>	<p>M1) DS0B  M2) 19.2+3S  M3) DS0A  M4)19.2+FEC  M5)19.2+19.2+S</p>
Port	<p>Select DDSU Port—This command is used to select individual port displays for review or changes.</p> <p>The data rate and sync/async selection for the selected port is displayed and available for changes.</p> <p>Type "PORT" for the prompt:  <b>ENTER DIU 2140 PORT:</b></p> <p>Valid entries range from 1 to 5.</p> <p>After first selecting the desired mode, select each of the available ports and verify the correct settings for data rate and sync/async.</p>	<p>1  2  3  4  5</p>
B1—B6	<p>Baud Rate for Selected Port—Depending on the mode selected, the data rate for some of the ports may be user selectable. To set the data rate for a port, first select that port using the PORT command, then enter one of the following commands:</p> <p>B1—for 300 bits per second  B2—for 600 bits per second  B3—for 1200 bits per second  B4—for 2400 bits per second  B5—for 4800 bits per second  B6—for 9600 bits per second</p> <p>A data rate of 19,200 bit/s may be selected only by selecting a mode which dictates it such as Mode 2, 4, or 5.</p>	<p>B1) 300 bit/s  B2) 600 bit/s  B3) 1200 bit/s  B4) 2400 bit/s  B5) 4800 bit/s  B6) 9600 bit/s</p>

Command	Description	Options
Sync	<p>Synchronous Transmission—Type “SYNC” while the port is selected.</p> <p>Each port may be set to SYNC independently of every other port.</p> <p>After first selecting the desired Mode, select each of the ports to be used and verify the correct settings for sync.</p> <p>If SYNC mode is selected, the DIU 2140 will provide both transmit clock and receive clock. The DIU 2140 will not accept an external clock and use that clock to time a T1 circuit. Also, in SYNC mode, if Request To Send (RTS) is not asserted by the DTE on pin 4 of the RS-232 interface, no data will be sent.</p> <p>If your application requires synchronous operation and your DTE does not assert RTS, contact Verilink Tech Support at (800) 837-4546.</p> <p>The DIU 2140 does not convey control lead state changes from end to end. Applications which require toggling control leads will not operate over the DIU 2140.</p>	
Async	<p>Asynchronous Transmission—Type “ASYNC” while the port is selected.</p> <p>Each port may be set to ASYNC independently of every other port.</p> <p>After first selecting the desired Mode, select each of the ports to be used and verify the correct settings for async.</p> <p>If your application requires asynchronous operation and your DTE does not assert RTS, contact Verilink Tech Support at (800) 837-4546.</p> <p>If ASYNC is selected, the port will support eight data bits, no parity, and one stop bit. In ASYNC mode, the state of RTS is ignored and all transmit data is sent.</p> <p>The DIU 2140 does not convey control lead state changes from end to end. Applications which require toggling control leads will not operate over the DIU 2140.</p>	
SNE	<p>Set Near End Loopback—The DIU 2140 supports a bidirectional near end loop which may be used on only one channel at a time.</p> <p>First select the desired channel using the port command. To put up a near end loop type “SNE”. The user is asked to confirm:</p> <p><b>Are you sure (Y/N)?</b></p> <p>The local DTE should see its own data and the far end DTE should also see its data, but through the entire T1 circuit.</p> <p>During a near end loop the STAT led on the DIU 2140 will be amber.</p>	
CNE	<p>Clear Near End Loopback—To clear the near end loop type “CNE”. The user is asked to confirm:</p> <p><b>Are you sure (Y/N)?</b></p> <p>During a near end loop the STAT led on the DIU 2140 will be amber.</p>	
X	<p>Exit Menu—Type “X” to return to the controller module Main Menu.</p>	

---

# Chapter 4

## Diagnostics

Diagnostics routines are included in the Configuration Menu and all alarms are functions of the CSU. Controller card(s) poll the various modules for alarms. If alarm reporting is enabled for the node and for the module(s), the node controller card retrieves and sends the alarm to Access Manager 2000, Node Manager 2000, or an SNMP agent.

---

### LED Indicator

The DIU 2140 front panel (Figure 4-1) has a STATUS LED to aid in troubleshooting.

Figure 4-1 DIU 2140 Front Panel



---

### STAT LED

The STAT (DIU 2140 status) LED is a tri-color indicator that displays one of the following conditions for each data port:

---

**NOTE:** *If the STAT LED has a low-battery alarm and a loss-of-signal alarm at the same time, the LED flashes in the following order:*

*Solid Green (6 sec.), 2 Red Flashes, Out (2 sec.), 3 Red Flashes (repeated).*

---

- **Green**—DIU is working properly (normal operation).
- **Flashing Green**—DIU is being accessed by a master NCC or SCC thumbwheel switch.
- **Red**—DIU is not in sync with the far-end DIU.
- **Amber**—Associated data channel is under test by an operator (a test signal is being applied by the DIU).
- **Flashing Red**—Power-up self test failure.
- **Flashing Red and Amber**—DIU has failed an operator-initiated data channel test.
- **Not Lit**—DIU is not powered up (power is lost).

## Diagnostics

Limited diagnostics are available from the DIU 2140 for testing data connections and signalling. More diagnostics for the circuits are available from the controller module **Main Menu**. See the controller module user manual for more information.

### Data Channel Loopbacks

The DIU 2140 has a data channel loopback to isolate data channel failures. [Figure 4-2](#) shows this loopback. When the loopback is activated, it provides two simultaneous connections:

- One toward the data equipment
- One toward the network

On the equipment side, the data equipment transmitter is connected to the receiver through the DIU interface driver and receiver circuits. Use this path to verify operation of customer data equipment and the interface cabling to the DIU.

When a data channel loopback is activated, the incoming channel data from the network is looped back toward the far-end. This path provides end-to-end data-circuit channel testing through the network, and DIU and CSU at each end.

**Figure 4-2 DIU 2140 Data Channel Loopbacks**

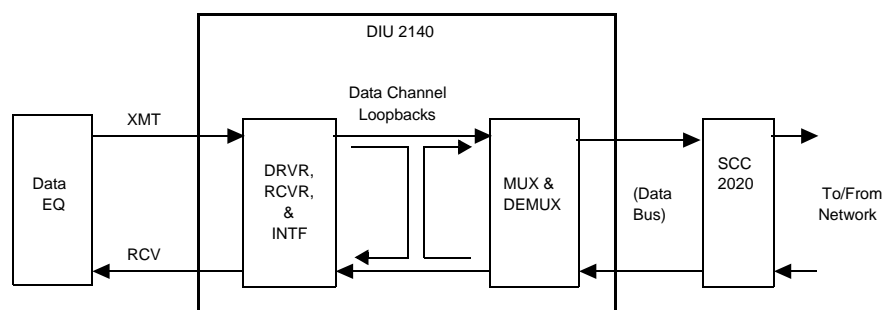

The DIU data channel loopback can be activated and deactivated on any data port. When this loopback is activated, only the selected data port is tested. The other data ports continue to operate normally and transmission service is not affected.

---

# Index

---

## B

battery, clock chip ii

## C

Cables 2-2

Configuration / Diagnostic Menu 2-3, 3-2

connection methods 1-2

CSU Interfaces 1-4

## D

data buses 1-4

Data Channel Loopbacks 4-2

data interface modules 1-3

data interface modules (DIMs) 1-3

Diagnostics 4-2

DIM 2232 1-3

DIU 2140 Configuration 3-1

DIU data buses 1-4

DIU transmit functions

test signal generator 1-4

## F

front panel 1-3

## I

Installation 2-1

## L

LED Indicator 4-1

## M

Main Menu 2-2, 3-1

SCC 2-2

management modules 1-2

connection methods 1-3

NCC 2020 1-2

NCC 2130 1-2

NCM 2000 1-2

SCC 2020 1-2

SCC 2130 1-2

## N

Near End Loop LED 4-1

## Q

Quick Set-Up 2-1

Quick Set-up 2-1

## R

Receive Side Functions 1-4

## S

Specifications 1-5

STAT LED 4-1

## T

transmit side functions 1-4





*Building tomorrow into today's networks*

June 1998  
P/N 880-501614-001-A

VERILINK CORPORATION  
MADISON, ALABAMA 35758  
TEL: (800) 837-4546